



STRATA*mini*

Enjoyment Guide

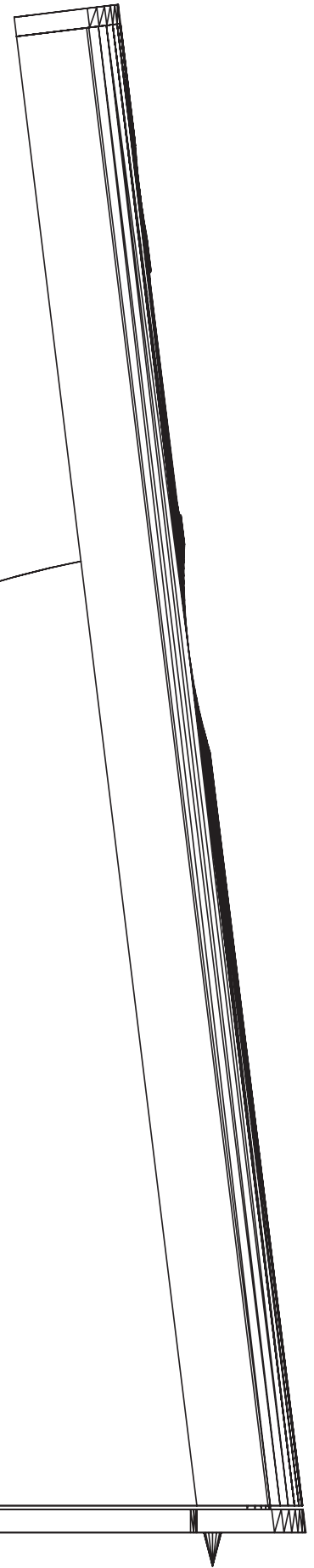
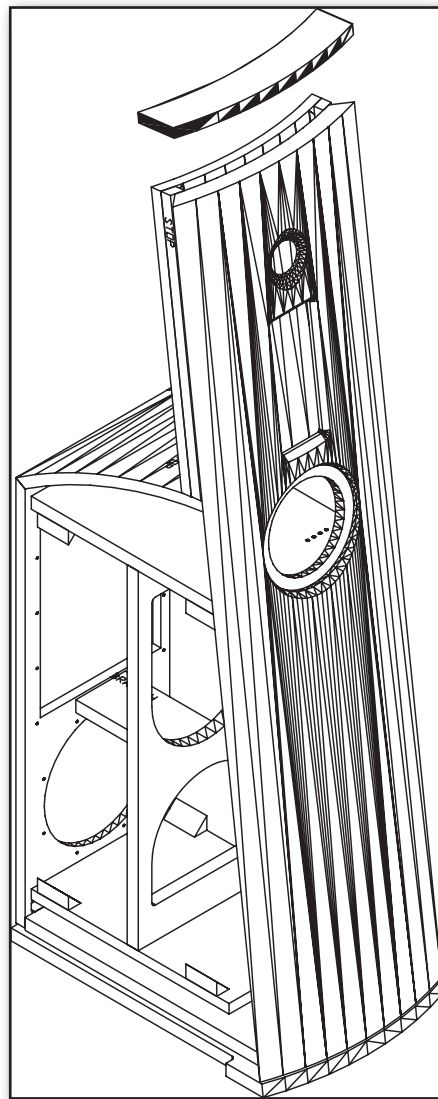

Table of Contents

Safety Precautions	3
Thank You for your Strata Mini purchase	4
Unpacking and Product Registration	5
Inventory	5
Getting Started	5
Limited Warranty Coverage	5
Register your Strata Mini speakers at AV123.com	5
Features and Descriptions	6
The Strata Mini	6
Speaker Placement Considerations	7
Front (Left and Right) Speaker Placement	7
Should I "Toe In" the Strata Mini speakers?	8
Connections	9
Speaker Binding Post Connections	9
Powered 8" Woofer Connections	9
Speaker Level Inputs	9
Line Level Inputs	10
Connections for Home Theater Users	10
Wiring for Correct Polarity	10
Setup of the 8" Woofer Amplifier	11
Setting the 8" woofer Level	11
Configuration and Reference Settings	11
Establishing the Reference Levels of the Full Range Speakers	11
8" Woofer Crossover and Phase Adjustments	12
Setting 8" Woofer Crossover	12
Setting 8" Woofer Phase	13
Caring for your Strata Mini speakers	13
Technical Specifications	14
Limited Warranty and Return Policies	15
Service Assistance for Strata Mini loudspeakers	15

Safety Precautions

At AV123, we don't want to see any of our customers experience the inconvenience or unfortunate mishap of a precaution that was ignored. Please review the following precautions so you may enjoy your Strata Mini speakers without unnecessary damage or misuse.

**IMPORTANT!
PLEASE READ THESE
INSTRUCTIONS
CAREFULLY**

- 1) If you suspect you have a component failure in your speakers at any time, please call AV123 for help. Our experts can assist you in diagnosis and, if necessary, provide you with field repair parts where applicable. Our goal is your complete satisfaction.
- 2) Do not lift these speakers if you feel strain or they are just plain too heavy for you. The weight of each Strata Mini speaker is listed in the Technical Specifications section of this manual for your reference.
- 3) When lifting these speakers, do so with caution. If you need to use a cart or hand truck to move them around to their final destination, please do so with care and caution. Odd shaped boxes may require a 2 person lift even if the weight of the box does not seem prohibitive.
- 4) Do not install these speakers near water (or expose them to water) or any other liquids. If you have a place in the basement that floods or a leaky roof in certain spots, do not install your Strata Mini speakers (or any other home entertainment equipment) in that location. Use good judgement, but if you are not sure if your chosen location is acceptable, chances are you should call us. It never hurts to ask.
- 5) Do not poke, prod, or "heavily pet" these speakers. Do not set drinks on them (or it's just about guaranteed the drinks will leave a ring and spill too). Do not use the speakers as tables or chairs. Whenever possible, ask the kids and pets to play elsewhere than on (or directly in front of) the speakers. All of these suggestions come from many years of experience by our AV123 experts so you can trust the origin.
- 6) Do not install these speakers near a heat source such as a floor heater, space heater, fireplace, stove, heat register, active volcano, or any other device (including amplifiers) that may radiate heat.
- 7) Plug the electrical power cord for the integrated amplifier into a line conditioner or connect to an unswitched 110VAC wall outlet directly. Do not connect the 8" woofer amplifier's power cord into a "power strip". This ensures the best performance and avoids power delivery related problems.
- 8) Do not plug the Strata Mini speaker binding posts into the wall, EVER. Some people think it's a great way to test the excursion limits of a low frequency driver but in truth it's very dangerous. Just hook them to the amplifier outputs as recommended in this manual please.
- 9) These speakers in a home entertainment environment can easily produce high sound pressure levels that can impair hearing if you (or other listeners) undergo extended exposure. Use caution when listening at high volumes and, by all means, please discontinue use if your ears are ringing. If you must play these speakers at extremely high volumes, we recommend the use of OSHA approved hearing protection.
- 10) Please read and follow the instructions in this manual. Keep this manual for future reference.

Thank You for your Strata Mini purchase

Dear Home Entertainment Enthusiast,

At AV123, our absolute highest priority begins and ends with you, the customer. As our valued customer, you can rest assured that if you're not 100% satisfied with your purchase within 30 days from your original receipt date, you may return your product(s) for a prompt refund in full (excluding shipping charges) with no explanation necessary. Coupled with the expert advice on our website and through our trained advisors, there is simply not a safer way or place to buy today.



Mark with his pride and joy, Granddaughter Gracie after her performance in The Nutcracker

We make every effort to make sure your home entertainment needs are met with the great products and unbeatable service we offer every single day. Not only do we give you the tools and the resources to fully evaluate your purchase before your order is placed, we back this up after the fact by allowing you a full month to audition our products in your own home before your final decision is made. AV123 simply does not engage in misleading and high-pressure sales tactics. In the long run, we know it's not the way either one of us wants to do business. We want customers for a lifetime.

The Strata Mini is a dream come true. The hybrid design will astound you with its ability to be utterly delicate yet deliver visceral impact when asked. This is thanks to its combination of planar magnetic drivers operating in concert with "selected" cone drivers. The planar magnetic midrange and tweeter are custom built to our specifications along with the French-designed and renowned Atohm 5.25" mid-bass coupler located in it's own critically damped chamber. We hand this off to a custom damped and treated paper cone 8" woofer - powered by an internal class A/B 350 watt amplifier.

We want you to know that The Strata Mini is exquisite in every measure and meaning of the word. The Strata Mini is designed for intimate settings – not cathedrals. What you can expect is an emotionally engaging and utterly immersive experience on an intimate level. The elegantly designed cabinet with real Rosewood veneers, narrow width (minimizes visual impact) and sloped baffle will be sure to carry an elegant feel to your room and extend itself gracefully to the visual realm even at rest.

We've done our best to provide you with products and services meeting or exceeding your expectations. However as good as our products are, they do not match our dedication to each and every sale. Should you need any further assistance in the future with your A/V system, you can bet that AV123 will be there supporting and assisting you as you make your way to your next level of audio/visual enjoyment.

Mark L. Schifter
President

Unpacking and Product Registration

The Strata Mini speakers should reach you in absolutely perfect condition. If you notice any shipping damage or other issues upon unpacking the unit, please contact AV123 immediately. We have gone out of our way to ensure the speakers are shipped with the utmost care, but if that is not the case when they arrive at your door, please do not hesitate to contact us.

Inventory

Your Strata Mini speakers are carefully hand packaged utilizing molded foam inserts to protect their fine furniture grade finish. When removing the speakers from the box, hold the wood sides of the cabinet, rather than the front and back. It is important to save all the packing materials and the box in case your Strata Mini speakers ever needs to be moved or shipped back to AV123 for service or repairs.

All Strata Mini speakers include rubber mounting feet, floor spikes, and hardwood floor protectors in the packaging to decouple the speaker from whatever type of flooring material you have. **If you have low seating, you want to install the REAR SPIKES only to effectively lower the tweeter height.**



Rubber Feet

Getting Started

Once you have established that all of your speakers and accessories are present and accounted for, we ask that you **PLEASE READ THIS MANUAL FIRST** before installing and positioning the speakers. We have thoughtfully assembled many useful tips to maximize the performance of your Strata Mini speakers in your home entertainment environment.

Limited Warranty Coverage

All products sold through AV123 carry a limited manufacturer's parts and labor warranty. All Strata Mini loudspeakers are guaranteed to be free from manufacturer's defects for a period of one year from the date of purchase. Make sure that you keep your sales receipt. It is the only way for AV123 to establish the duration of your limited warranty and it may come in useful for insurance purposes if your Strata Mini speakers are ever damaged or stolen.

Register your Strata Mini speakers at AV123.com

Please take a moment to visit AV123.com and register your Strata Mini purchase. When you go online and register your product, AV123 will extend the warranty by an additional two years. This, in addition to the 1 year limited warranty is a total of 3 years! This extended warranty is free simply for registering within 60 days of your purchase. We urge you to take advantage of this offer. Warranties apply only to the original owner and are non-transferable. See page 15 for limited warranty details.

Features and Descriptions

The Strata Mini

- Floor Standing Loudspeaker
- Four Way, Four Driver Direct Radiating System

Cabinet

- South American Rosewood Veneer
- Internal CNC Machined MDF Skeleton
- Folded Vent for 8" Woofer Enclosure

Drivers

- Planar Magnetic 1" Tweeter
- Planar Magnetic 8" Midrange
- Atohm 5.25" Midbass Coupler
- Custom 8" Woofer

Amplifier

- Built-in 350 Watt Class A/B 8" Woofer Amplifier
- Adjustable Crossover
- Adjustable Gain
- Variable Phase (0-180 degrees)
- High and Low Level Inputs/Outputs

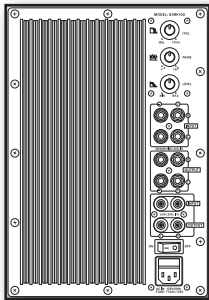

The built-in 350 watt amplifier in the base of the Strata Mini has all of the features needed to ensure low, linear sub-bass output that blends effortlessly with the other drivers in the speaker

Passive Crossover Network

- Custom Designed by Mark Schifter and Danny Richie
- Air Core Inductors
- Polypropylene Capacitors
- Non-Inductive Wirewound Resistors
- Fourth Order Slopes on High Frequencies
- Second Order Slopes on Low Frequencies

Crossover Points

- 8" Woofer = 27Hz to User Definable
- 5.25" Mid Bass Coupler = 80Hz to 650Hz
- 8" Planar Magnetic Midrange = 650Hz to 4100Hz
- 1" Planar Magnetic Tweeter = 4100Hz to 35KHz

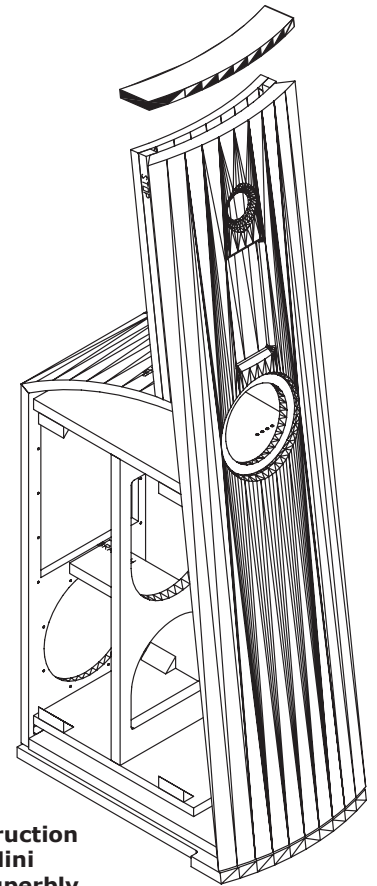

The cabinet construction of the Strata Mini loudspeakers is superbly executed with the finest materials and exacting tolerances



Planar Magnetic Midrange and Tweeter drivers coupled with an Atohm 5.25" Midbass driver create a very intimate, detailed sound characteristic

Speaker Placement Considerations

Achieving the best performance from your Strata Mini speakers requires several details to follow when setting them up in their new environment. Tips and suggestions for the most desirable placement techniques are listed throughout this section.

Front (Left and Right) Speaker Placement

Regardless of physical placement, always try to place your main speakers (LEFT and RIGHT) with the tweeter positioned on axis around ear level. This yields excellent sound quality results. Physical placement of front speakers should be along the same wall of your listening/viewing room. Although we've seen successful installations that didn't follow these guidelines, they're generally more problematic in terms of system response and accurate theater sound reproduction. Our advice - why re-invent the wheel?

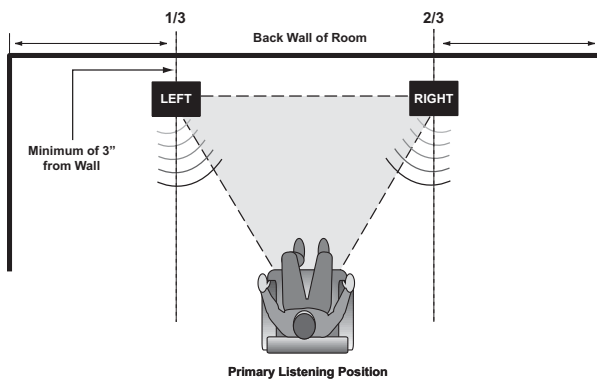

Use the "Rule of Thirds" whenever possible as a starting guide. This suggests that the best placement for your LEFT speaker is approximately 1/3 of the way along the wall behind your speakers. Similarly, the best place for the RIGHT speaker is usually 2/3 of the way across the same wall. If at all possible, move the speakers out from the back wall. Although all rooms are different, we recommend a minimum wall-to-rear-of-speaker distance of 12 inches. Whatever distance you finally select, use a tape measure to make

sure that each speaker is placed at the same distance from the back wall. With that same tape measure, make sure the speaker-to-listening position is the same for each speaker, too. If there's a conflict here (as would happen with an irregular wall behind the speakers), we suggest that you equalize the distance between front of the speakers and your favorite listening position. If that places one speaker closer to the wall behind it than the other, don't be too concerned.

Remember that the "Rule of Thirds" is a basic guideline only. Some acousticians recommend placing the main (LEFT and RIGHT) speakers so that they form an equilateral triangle with the prime listening position. This is as close to ideal. Notice different distances between speakers and left and right sidewalls. It's worth trying for this ideal, but don't get overly concerned if your room doesn't allow this precision.

Side walls have a major impact on the sound you hear. Ideally, you should not place your main speakers close to them. Remember that the "Rule of Thirds" gives you a good starting position, but **you should feel free to experiment**. Ideally, try not to place your main speakers so they're *exactly* the same distance from the closest side walls. A bit of asymmetry here is actually preferable. *Symmetrical* placement generally results in larger *standing waves* in the room that reinforce certain frequencies and diminish others.

When you take the time to place your speakers properly, you'll realize better "imaging" (the apparent lateral placement of individual instruments or voices), and more depth or "layering". You'll hear those advantages because you'll be avoiding the aural confusion caused by so-called "first reflections" that complicate our perceptions when speakers are too close to a wall's large, flat, reflecting surface.

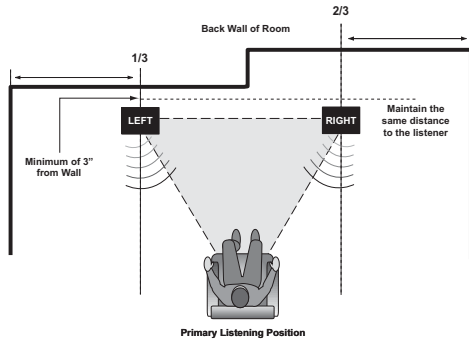

Placement in rooms with odd shaped back walls should still align the speaker distances equally to the listening position. Don't rely on electronic time delay correction to fix these problems whenever possible as the difference in room shape cannot always be accounted for with a straight time delay.

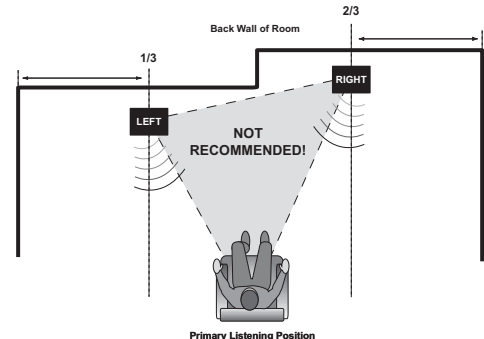

Should I "Toe In" the Strata Mini speakers?

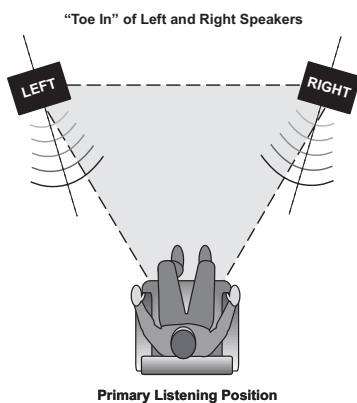

That's a question many enthusiasts ask us at AV123. Some people like to "toe-in" their main speakers to get better performance. This simply means aiming both Left and Right speakers so that they point more towards the prime listening/viewing position rather than straight ahead. "Toe-in" can improve imaging and add a sense of spaciousness to the sound. In a 2-channel system (with no discrete center channel speaker), this is especially effective in creating a "phantom" center channel effect. In addition to imaging improvements, toe-in can also change your speaker's tonal balance (or timbre).

For that reason, you may want to play with toe-in to get the most out of your speakers. Some time spent experimenting here can yield a better match to your room's acoustic properties, provide a clearer, more precise phantom center image, or just better suit your own listening preferences. If you are using Strata Mini loudspeakers as part of a home theater system and actually have a center speaker operating in a matrix mode like Dolby PLIIx, DTS Neo:6, or another "simulated" multi-channel mode, the toe in positioning can also help blend that center channel.



Connections

For the best sound quality and signal transfer, AV123 recommends a minimum of 16 gauge high quality, multi stranded, oxygen free copper speaker cables. Speaker wiring connections are accomplished through the 5-way binding posts.

Speaker Binding Post Connections

Connect the amplifier's LEFT channel outputs to the positive and negative input terminals of the LEFT Strata Mini speaker, being sure to observe correct polarity. Connect the amplifier's RIGHT channel outputs to the positive and negative input terminals of the RIGHT speaker, again being sure to observe correct polarity. Refer to your amplifier's connection manual to ensure the component is suitable for driving 8 Ohm per channel loads.



To Amplifier Negative Output To Amplifier Positive Output

Powered 8" Woofer Connections

Although there is technically no connection necessary to the driver itself (we've already done that part) you do have to choose connections for the audio input to the Strata Mini's 8" Woofer amplifier. There are several ways in which to accomplish this:

Speaker Level Inputs

After careful consideration, we at AV123 have determined that the **very best sounding method** for connecting the active 8" Woofer with the other speakers in the Strata Mini loudspeaker via high level inputs is to do the following:

- 1) Connect the speaker binding posts **directly to the outputs of your main amplifier**. The left channel from the amplifier/receiver will connect to the LEFT + and - binding post, then the right channel from the amplifier/receiver will connect to the RIGHT + and - binding post.
- 2) Next, connect a second pair of speaker wires from each binding post to the respective RIGHT **high level input** on the built in amplifier. Using the right channel only is AV123's recommended method because leaving the left high level channel open is used for a noise cancellation trick if the 8" Woofer amplifier experiences powerline "hum". See photo at right for an example.

Right channel speaker binding post connectors (one connection per side)

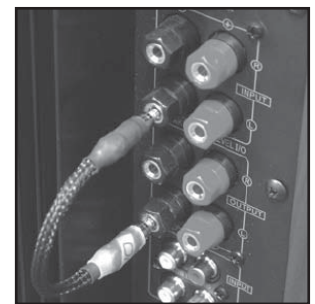
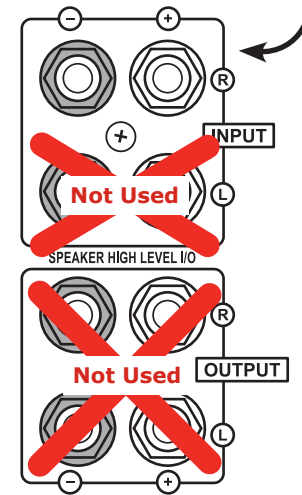

Looping the left negative input to the left negative output will help in any situation where a powerline "hum" is present

By directly wiring the binding post inputs in parallel to the amplifier, the bottom octaves reproduced by the 8" Woofer blend smoother with the output than if an additional passive filter were used.

Line Level Inputs

If your receiver or preamplifier has a set of full range RCA line outputs that are not already being used, you can connect these into the **LEFT Line Input jack on the left speaker** and then the **RIGHT Line Input jack on the right speaker**.

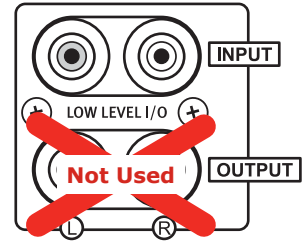

Connections for Home Theater Users

If you are using Strata Mini loudspeakers with a home theater receiver that contains discrete processing (such as Dolby Digital and/or DTS) you **may** have only a "SUB" line output to use. If this is the case, you have 3 choices:

- 1) Check to see if the receiver has full range RCA line outputs available. If so, use these outputs connected to the "Line Inputs" of the built in amplifier and set the front speaker setting on in the receiver's setup menu to "LARGE".
- 2) Use the full range high level input as described in the previous section, also setting the front speakers to "LARGE".
- 3) Use the SUB output, split with a "Y" adapter to each "Line Input" and take note of the crossover setting directions when using a SUB output covered in the next section. When using this connection option, you will have upstream filtering by the crossover in the preamplifier/processor section.

Wiring for Correct Polarity

When connecting the speakers to the amplifier you need to observe the proper polarity. This simply means that you should connect the positive terminal on your receiver or amplifier (may be marked "+" or be colored red) to the positive terminal (red) on your Strata Mini speaker. Connect the negative terminal on the amplifier ("- " or black) to your speaker's negative (black) terminal. Don't worry about damaging anything if you make a mistake here. Sound quality will suffer but you won't ruin anything. You can definitely hear a difference if it gets connected backwards though. It really affects the imaging and low frequency response in a negative way, so double check your work!!

When connecting the speaker wiring you'll see that it has two different conductors - silver and copper colored are the most common. If you can't see the conductors themselves, look closely at the insulation. You'll notice that the insulation over one conductor is different than that over the other conductor - one will have slight molded ridges in it, the other will be smooth, for example. It really makes no difference which one you pick for positive or negative, **just be consistent!** Other speaker cable may be marked with designated positive and negative conductors.

Setup of the 8" Woofer Amplifier

Proper setup of the 8" Woofer amplifier in Strata Mini loudspeakers ensures that the blend of low to high frequency will be optimized when you finally sit down to enjoy them.

Setting the 8" Woofer Level

Although you **can** setup levels by ear, accurate calibration of 8" Woofer levels relative to the other speakers in the Strata Mini require an SPL meter. Radio Shack sells a digital meter that works very well for this purpose (P/N 33-2055) and it's about \$50. Set the meter on 'slow' and "C" weighting. The dial should be set at either 70 or 80 depending on your preamplifier/processor or receiver's test tone reference output level. Consult your owner's manual to determine what reference point your unit uses (most use 75, so the 70 setting on the meter would be appropriate in that example). If you do not have a built in test tone generator, you can use a test CD that contains Pink Noise.



**Radio Shack
Digital SPL
Meter**

Each range setting on the Radio Shack 33-2055 meter will cover 20dB (10 above and 10 below). So a setting of 70dB would cover between 60-80dB range. If you are using another meter, consult the owner's manual for proper operation.

Configuration and Reference Settings

- 1) Begin by reviewing the calibration menu settings of your receiver or preamplifier/processor. If there is a speaker configuration menu, be sure the outputs for Strata Mini speakers are set to "LARGE".
- 2) Unplug the 8" Woofer input on each Strata Mini speaker. Exactly how this is done depends on whether you are using line level or speaker level inputs.

Establishing the Reference Levels of the Full Range Speakers

- 3) Set the volume control on your preamplifier/processor to the "00 dB" level. If your unit uses a positive number scale for volume instead of a minus-to-plus scale, just watch the meter until it reaches 75 or 85dB (depending on the recommended reference level of 70 or 80dB in the receiver or preamplifier/processor's owner's manual). Note this volume position because you will need to get back to it shortly.
- 4) Turn the volume way down and unplug the binding posts inputs that feed the high frequency speakers on both of the Strata Minis.

Setting 8" Woofer Level

- 5) Reconnect the 8" Woofer inputs that you disconnected in Step 2 to both Strata Mini loudspeakers.
- 6) The crossover on the each Strata Mini 8" Woofer should be set between 80Hz to 100 Hz as a starting point unless you have used the LFE 8" Woofer Output on your preamp/processor) - in which case the crossover will be left at the highest setting.

- 7) Begin by setting the 8" Woofer level using the dial labeled "LEVEL" on the built in amplifier to 12 o'clock. See diagram at right.
- 8) Raise the volume level on the preamplifier/processor so the test tone achieves the reference level you documented in Step 3. An assistant will be very helpful for this process because the meter location and 8" Woofer level adjustment location will be different. Keep in mind, the intended use of the Strata Mini loudspeakers are for intimate 2-channel listening so adjust the 8" Woofer level accordingly.
- 9) Once the 8" Woofer is calibrated to closely match the other speakers, small adjustments can be made easily using the 8" Woofer level control in your processor or receiver. If you find the need to go much above +2 or +3 consistently, we recommend adjusting the level control on each Strata Mini amplifier upward instead and using a lower number for reference level on the processor.

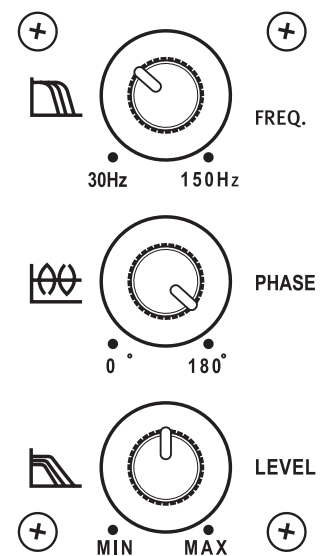

Crossover, Phase, and Level adjustments on the built-in amplifier with indications for "Starting Points" before you fine tune

8" Woofer Crossover and Phase Adjustments

After setting up the system reference levels on each Strata Mini, it's time to set the crossover (where applicable) and the phase dial (where necessary). This activity will round out the effectiveness of the 8" Woofer a seamlessly blended part of the four way Strata Mini system!

Setting 8" Woofer Crossover

The range of low pass crossover adjustment is 30-150Hz and is labeled "FREQ". If you do not have a dedicated output for the 8" Woofer such as on a home theater receiver, simply use the respective left and right line outputs into each Strata Mini line input for the respective channel. For the crossover setting, it is recommended to begin at the highest setting (150Hz) and slowly dial it down until it seems as if the bass is anchored in the front drivers rather than just the 8" Woofer. We strongly recommend settings around 80Hz-100Hz because this will allow a nice blend with the other Strata Mini mid and high frequency speakers without making either of them work too hard with reproducing the bulk of the low frequencies. If you are a traditional 2 channel enthusiast, this method is the preferred choice. See diagram shown above.

If your preamplifier/processor has a dedicated "LFE" or "SUB" output, then you should leave the crossover set to the maximum setting because the filtering function is handled upstream in the Dolby Digital/DTS processor. When your processor is not on a Dolby or DTS source format, it will make the necessary filtering for the LFE output so this input configuration will yield the best result for that equipment. If you are using Strata Mini loudspeakers in a home theater system, this is the method you should use. It is assumed however that most users of Strata Mini loudspeakers will do so in a strictly 2-channel environment as described in the previous paragraph.

The easiest way to test different methods and frequencies for crossing over your 8" Woofer is by using bass sweeps from the **AVIA Guide To Home Theater** DVD or even low frequency sweeps found on many test CDs. Specifically, the tones that descend in frequency from the individual high frequency speakers to the 8" Woofer are quite useful and effective. Using your SPL meter, watch for the smallest amount of overall needle fluctuation while you direct and descend the tones from the main speakers to the 8" Woofer going around your system. If you are not sure about how to do this or where to locate the AVIA or other test discs, please call AV123 at (877) 543-7500 for assistance or email us at support@av123.com.

Setting 8" Woofer Phase

The knob labeled "PHASE" controls the relative phase of the 8" Woofer to best reinforce the other loudspeakers in your system. Always make adjustments with BOTH Strata Mini 8" Woofers playing so you adjust in real time. Adjustments to phase will change the 8" Woofer interaction with the rest of the Strata Mini speaker system, providing the least cancellation, and thus the best response in any room. With SPL meter in hand (or, better yet, on a tripod in the listening position), play an 80Hz tone (for this exercise the crossover point must be set to 80Hz or above and turn the Phase knob slowly from "0" to "180." Watching your SPL meter, select the setting that results in the biggest peaks in sound pressure levels (i.e. reads highest on the meter). As this 8" Woofer is contained in close proximity with the other drivers in the loudspeaker, your main adjustment of phase will predominately serve to blend the reflected energy from the back wall where the 8" Woofer faces.

To verify your measurements, go back to the listening position and listen for yourself using music you know. If the bass from the loudspeaker seems to be coming from the front speakers rather than noticeably separated from them and reduced in output level, you have got it right. The optimum setting indicates the least amount of bass wave cancellation, and should be left alone after setting until the 8" Woofer or other speakers in your room are moved, or placement is altered in any way. With front speaker placement (where the sub faces the wall on the back), the "180" setting is usually best.

Caring for your Strata Mini speakers

Your Strata Mini speakers do not need much exterior maintenance other than an occasional dusting. Please use care with the black and wood veneer finish and treat them as you would a piano or fine furniture finish. The black finish on the Strata Mini speakers can be waxed with automotive carnauba wax if desired. With the satin black finish, waxing may even increase the gloss of the finish slightly! Wood veneer surfaces on Strata Minis can be cleaned with a damp cloth (using water) if necessary. We recommend the 3M Yellow Detail Cloth (part # 39016) for dust on both the black and wood veneer surfaces as it does not scratch the finish.

Technical Specifications

Strata Mini

System Description:	3.5 Way, 4 Driver Full Range Speaker
Enclosure Type:	Sealed for Midbass, Midrange, and Tweeter Vented, Rear Firing for Powered 8" Woofer
Frequency Response (+/-3dB):	27Hz- 35KHz
Nominal Impedance:	8 Ohms
Sensitivity:	86dB @ 1w/1m
Crossover Points:	8" Woofer = User Definable 5.25" Mid Bass Coupler = 80Hz to 650Hz 8" Planar Magnetic Midrange = 650Hz to 4100Hz 1" Planar Magnetic Tweeter = 4100Hz to 35KHz

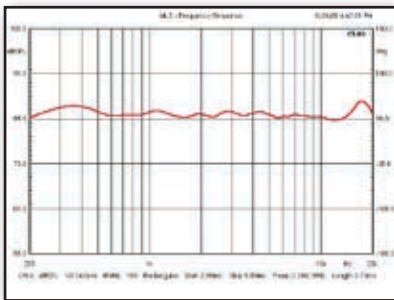

On Axis Frequency Response

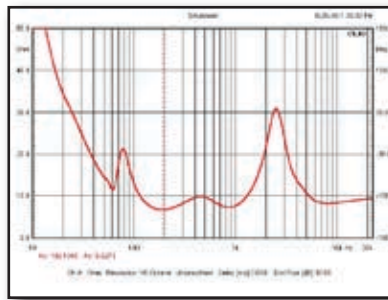

Impedance Response

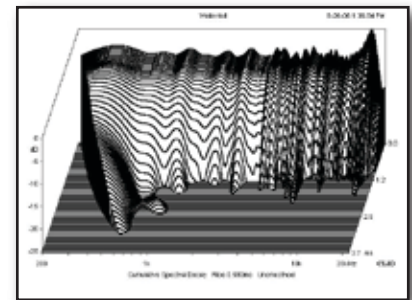

Spectral Decay

8" Woofer Amplifier

System Description:	Class A/B Plate Amplifier, Built In
Rated Power:	350 Watts
Input Type:	Speaker Level or Preamp Level Single Ended (RCA)
Crossover Frequency:	Adjustable, 30Hz- 150Hz
Electrical Power Requirement:	110VAC, 60Hz
Fuse Size/Type:	10 A, T10AL 125V

Weight and Dimensions

Raw Weight:	97 lbs each / 44.09 kg each
Shipping Weight:	280 lbs pair / 127.27 kg pair
Dimensions:	11.5" W x 47" H x 17.5" D / 29.2cm W x 119.4cm H x 44.5cm D

Limited Warranty and Return Policies

The Strata Mini speakers have been created to perform flawlessly for many years with regular use. As a result of this quality and craftsmanship, AV123 is proud to offer the following warranty policies to our customers:

- All products sold through AV123 carry a limited manufacturer's parts and labor warranty. This is for the piece of mind that, no matter what your purchase, there is some type of limited warranty on which you can depend. These will always be clearly stated with the product.
- All Strata Mini loudspeakers are guaranteed to be free from manufacturer's defects for a period of **one year** from the date of purchase. This warranty applies to the original purchaser of the Strata Mini product(s) and is non-transferrable.
- The Strata Mini warranty does not cover damage by misuse, abuse, neglect, unauthorized product modification, failure to follow the instructions outlined in this owner's manual, failure to perform routine maintenance, damage resulting from unauthorized repairs, or claims based upon misrepresentations of the warranty by the seller.
- If you visit av123.com and register your Strata Mini speaker purchase, AV123 will **extend the warranty by an additional two years**. This, in addition to the 1 year limited warranty is a total of 3 years! This extended warranty is free simply for registering **within 60 days of your purchase**. We urge you to take advantage of this offer.

Service Assistance for Strata Mini loudspeakers

AV123 will exchange all defective merchandise, including shipping charges to the original shipment destination, at no charge for up to 60 days after the date of purchase. After 60 days the product must be returned to AV123 for repair only and return shipping costs are the responsibility of the customer. Please note that BEFORE sending your Strata Mini speakers in for repair or replacement, you MUST call AV123 and obtain a return authorization (R/A) number. Before contacting AV123 to begin the R/A process, please have as detailed a description of the problem(s) you are experiencing and the conditions under which the problem(s) occur. Once you have obtained the R/A number, you must print this clearly on the outside of the box so it will be possible to determine from whom the Strata Mini speaker(s) came once the parcel arrives. Parcels arriving without an R/A number will be refused and returned freight collect.



Contact Information

Toll Free - (877) 543-7500
Website - www.av123.com
e-mail - support@av123.com



AV123
1001 Delaware Avenue, Suite C
Longmont, CO 80501

Toll Free - (877) 543-7500
Website - www.av123.com
e-mail - info@av123.com