



OPERATING INSTRUCTIONS

R-972
Audio/Video Receiver





IMPORTANT SAFETY INSTRUCTIONS

1. Read these instructions.
2. Keep these instructions.
3. Heed all warnings.
4. Follow all instructions.
5. Do not use this apparatus near water.
6. Clean only with dry cloth.
7. Do not block any ventilation openings.
Install in accordance with the manufacturer's instructions.
8. Do not install near any heat sources such as radiators, heat registers, stoves, or other apparatus (including amplifiers) that produce heat.
9. Do not defeat the safety purpose of the polarized or grounding-type plug. A polarized plug has two blades with one wider than the other.
A grounding type plug has two blades and a third grounding prong. The wide blade or the third prong are provided for your safety. If the provided plug does not fit into your outlet, consult an electrician for replacement of the obsolete outlet.
10. Protect the power cord from being walked on or pinched particularly at plugs, convenience receptacles, and the point where they exit from the apparatus.
11. Only use attachments accessories specified by the manufacturer.

12. Use only with the cart, stand, tripod, bracket, or table specified by the manufacturer, or sold with the apparatus.
When a cart is used, use caution when moving the cart/apparatus combination to avoid injury from tip-over.



PORTABLE CART WARNING



13. Unplug this apparatus during lightning storms or when unused for long periods of time.
14. Refer all servicing to qualified service personnel. Servicing is required when the apparatus has been damaged in any way, such as power-supply cord or plug is damaged, liquid has been spilled or objects have fallen into the apparatus, the apparatus have been exposed to rain or moisture, does not operate normally, or has been dropped.







Introduction

READ THIS BEFORE OPERATING YOUR UNIT

	CAUTION <small>RISK OF ELECTRIC SHOCK DO NOT OPEN</small>	
CAUTION : TO REDUCE THE RISK OF ELECTRIC SHOCK, DO NOT REMOVE COVER (OR BACK). NO USER-SERVICEABLE PARTS INSIDE. REFER SERVICING TO QUALIFIED SERVICE PERSONNEL.		

	This symbol is intended to alert the user to the presence of uninsulated "dangerous voltage" within the product's enclosure that may be of sufficient magnitude to constitute a risk of electric shock to persons.
	This symbol is intended to alert the user to the presence of important operating and maintenance (servicing) instructions in the literature accompanying the appliance.

WARNING : TO REDUCE THE RISK OF FIRE OR ELECTRIC SHOCK, DO NOT EXPOSE THIS APPLIANCE TO RAIN OR MOISTURE.

Caution regarding installation

Note : For heat dispersal, do not install this unit in a confined space such as a bookcase or similar enclosure.

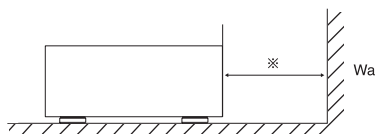
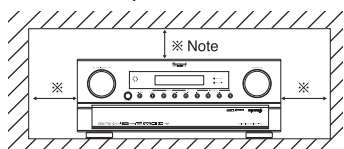

Do not block ventilation openings or stack other equipment on the top.

Note to CATV System Installer :

This reminder is provided to call the CATV system installer's attention to Article 820-40 of the NEC that provides guidelines for proper grounding and, in particular, specifies that the cable ground shall be connected to the grounding system of the building, as close to the point of cable entry as practical.

FCC INFORMATION

This equipment has been tested and found to comply with the limits for a Class B digital device, pursuant to Part 15 of the FCC Rules. These limits are designed to provide reasonable protection against harmful interference in a residential installation. This equipment generates, uses and can radiate radio frequency energy and, if not installed and used in accordance with the instructions, may cause harmful interference to radio communications. However, there is no guarantee that interference will not occur in a particular installation. If this equipment does cause harmful interference to radio or television reception, which can be determined by turning the equipment off and on, the user is encouraged to try to correct the interference by one or more of the following measures:

- Reorient or relocate the receiving antenna.
- Increase the separation between the equipment and receiver.
- Connect the equipment into an outlet on a circuit different from that to which the receiver is connected.
- Consult the dealer or an experienced radio/TV technician for help.

Caution : Any changes or modifications in construction of this device which are not expressly approved by the party responsible for compliance could void the user's authority to operate the equipment.

This Class B digital apparatus complies with Canadian ICES-003.

Cet appareil numérique de la Classe B est conforme à la norme NMB-003 du Canada.

FOR YOUR SAFETY

U.S.A
CANADA

120 V

Units shipped to the U.S.A and CANADA are designed for operation on 120 V AC only.

Safety precaution with use of a polarized AC plug. However, some products may be supplied with a nonpolarized plug.

CAUTION : To prevent electric shock, match wide blade of plug to wide slot, fully insert.

ATTENTION : Pour éviter chocs électriques, introduire la lame la plus large de la fiche dans la borne correspondante de la prise et pousser jusqu' au fond.



ENERGY STAR® is a U.S. registered mark. As an ENERGY STAR® Partner, Sherwood has determined that this product meets the ENERGY STAR® guidelines for energy efficiency.

CAUTION

- Leave a space around the unit for sufficient ventilation.
- Avoid installation in extremely hot or cold locations, or in an area that is exposed to direct sunlight or heating equipment.
- Keep the unit free from moisture, water, and dust.
- Do not let foreign objects in the unit.
- The ventilation should not be impeded by covering the ventilation openings with items, such as newspapers, table-cloths, curtains, etc.
- No naked flame sources, such as lighted candles, should be placed on the unit.
- Please be care the environmental aspects of battery disposal.
- The unit shall not be exposed to dripping or splashing for use.
- No objects filled with liquids, such as vases, shall be placed on the unit.
- Do not let insecticides, benzene, and thinner come in contact with the set.
- Never disassemble or modify the unit in any way.
- Notes on the AC power cord and the wall outlet.
- The unit is not disconnected from the AC power source(mains) as long as it is connected to the wall outlet, even if the unit has been turned off.
- To completely disconnect this product from the mains, disconnect the plug from the wall socket outlet.
- When setting up this product, make sure that the AC outlet you are using is easily acceptable.
- Disconnect the plug from the wall outlet when not using the unit for long periods of time.



**CONTENTS**

• IMPORTANT SAFETY INSTRUCTIONS	2
• Introduction	
READ THIS BEFORE OPERATING YOUR UNIT	3
• System Connections	5
• Front Panel Controls	17
• Universal Remote Controls	19
OPERATING COMPONENTS WITH REMOTE CONTROL	21
REMOTE CONTROL OPERATION RANGE	21
LOADING BATTERIES	21
USING FUNCTIONS OF REMOTE CONTROL	22
• ROOM 2 Remote Controls	
REMOTE CONTROL OPERATION RANGE	31
LOADING BATTERY	31
• Operations	
LISTENING TO A PROGRAM SOURCE	32
QUICK SETUP	34
SURROUND SOUND	37
ENJOYING SURROUND SOUND	39
LISTENING TO RADIO BROADCASTS	43
LISTENING TO XM SATELLITE RADIO	45
(XM Satellite Radio (only for North America))	
PLAYING MUSIC FILES	48
RECORDING	51
DIGITAL AUDIO RECORDING WITH MD RECORDER	52
OTHER FUNCTIONS	53
MULTI ROOM OPERATION	54
• OSD Menu Settings	56
SETTING THE SYSTEM SETUP	58
SETTING THE SPEAKER / LISTENING SETUP	61
SETTING THE INPUT SETUP	69
SETTING THE SOUND PARAMETER	75
SETTING THE MULTI ROOM CONFIGURATION	77
SETTING THE ADVANCED CONFIGURATION	79
SETTING THE QUICK AUDIO REFERENCE / ADJUSTMENT	81
• Troubleshooting Guide	83
• Specifications	84
• Setup Code Table	85





System Connections

- Please be certain that this unit is unplugged from the AC outlet before making any connections.
- Since different components often have different terminal names, carefully read the operating instructions of the component connected.
- Be sure to observe the color coding when connecting audio, video and speaker cords.
- Make connections firmly and correctly. If not, it can cause loss of sound, noise or damage to the receiver.

ENGLISH

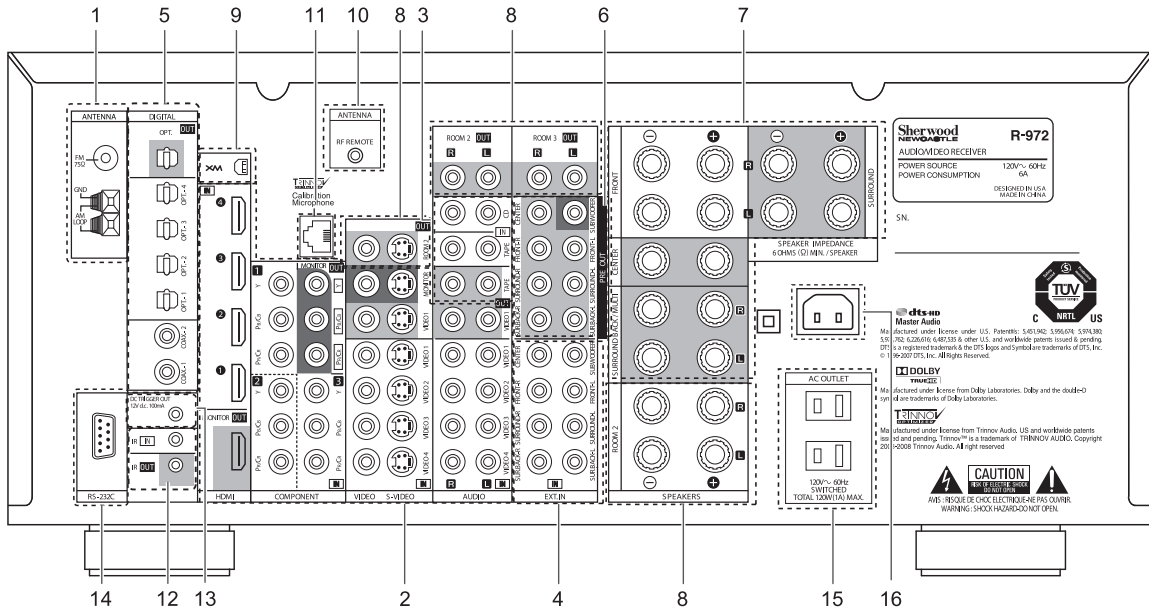

1. CONNECTING ANTENNAS

FM Indoor Antenna

FM Outdoor Antenna

- Change the position of the FM indoor antenna until you get the best reception of your favorite FM stations.
- A 75Ω outdoor FM antenna may be used to further improve the reception. Disconnect the indoor antenna before replacing it with the outdoor one.

AM Loop Antenna

AM Outdoor Antenna

- Place the AM loop antenna as far as possible from the receiver, TV set, speaker cords and the AC input cord and set it to a direction for the best reception.
- If the reception is poor with the AM loop antenna, an AM outdoor antenna can be used in place of the AM loop antenna.





2. CONNECTING VIDEO COMPONENTS

- The jacks of VIDEO 1 may also be connected to a DVD recorder or other digital video recording component. For details, refer to the operating instructions of the component to be connected.
- The jacks of VIDEO 2/VIDEO 3/VIDEO 4 can also be connected to an additional video component such as a cable TV tuner or satellite system.
- Connect the jacks of VIDEO 3/VIDEO 4 to the video component in the same way.

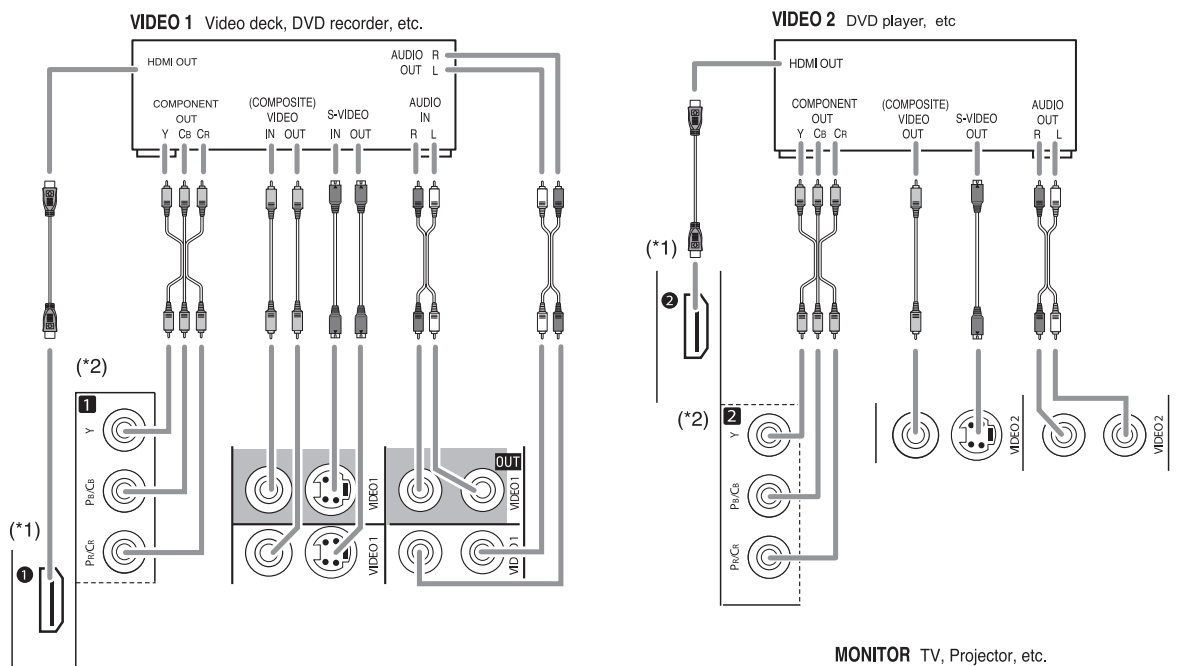

■ HDMI (High Definition Multimedia Interface) connection : (*1)

- You can connect the source component (DVD player, etc.) to the display component (TV, projector, etc.) through this receiver with using a commercially available HDMI cord.
- The HDMI connection can carry uncompressed digital video signals and digital audio signals.
- The HDMI video stream signals (video signals) are theoretically compatible with DVI-D. When connecting to a TV monitor, etc., equipped with DVI-D connector, it is possible to connect using a commercially available HDMI-DVI converter cord. Since the HDMI-to-DVI connection cannot carry any audio signals, you should make audio connections to play the audio signals on the component equipped with DVI-D connector. (For details, refer to the operating instructions of its.)
- If you connect the HDMI INs to your video components, it is easier to do so following the default settings.
- If your HDMI connection is different from the default setting, you should assign the HDMI INs you used with the "When selecting the HDMI Assign" procedure on page 70.
- The default settings are as follows :
HDMI 1 : VIDEO 1, HDMI 2 : VIDEO 2, HDMI 3 : VIDEO 3, HDMI 4 : VIDEO 4

■ Copyright protection system

- This unit supports HDCP (High-bandwidth Digital Contents Protection), technology to protect copyright of digital video signals against illegal duplication. HDCP must also be supported on the components connected to this unit.
- This unit is HDMI Ver. 1.3 compatible.
- HDMI, the HDMI logo and High-Definition Multimedia Interface are trademarks or registered trademarks of HDMI licensing LLC.

MONITOR TV, Projector, etc.

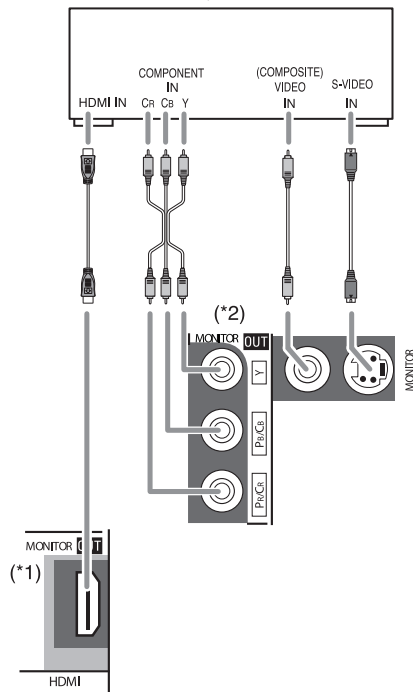



Continued

■ Notes :

- For stable signal transfer, we recommend using HDMI cords that are a maximum of 5 meters in length.
- Among the components that support HDMI, some components can control other components via the HDMI connector. However, this unit cannot be controlled by another component via the HDMI connector.
- The audio signals from the HDMI connector (including the sampling frequency and bit length) may be limited by the component that is connected.
- The video signals will not be output properly if a component incompatible with HDCP is connected.
- If the resolutions of the video signals which are output from the MONITOR OUTs and your monitor TV are not matched, the picture is not clear, natural or displayed. In this case, change the setting of the resolution on either this unit or the source component (DVD player, etc.) to one which the monitor TV can handle. (For details, refer to "When selecting the Video Scaling" on page 59 or the operating instructions of the source component.)
- When you want to enjoy only the picture on your TV, not the sound, you should set the HDMI Audio Output to Off not to output the digital audio signal from the HDMI MONITOR OUT of this receiver. (For details, refer to "When selecting the HDMI Audio Output" on page 60.)

■ Component video input default settings: (*2)

- If you connect the COMPONENT VIDEO INs to your video components, it is easier to do so following the default settings.
- If your component video connections are different from the default setting, you should assign the COMPONENT VIDEO INs you used with the "When selecting the Video Assign" procedure on page 70.
- The default settings are as follows:
COMPONENT IN 1 : VIDEO 1, COMPONENT IN 2 : VIDEO 2, COMPONENT IN 3 : VIDEO 3
- There are three types of video jacks (COMPONENT, S-VIDEO, (composite) VIDEO) for analog video connections and the HDMI connectors for digital video and audio connections.
Connect them to the corresponding video jacks according to their capability.
- For your reference, the excellence in picture quality is as follows : "HDMI" > "COMPONENT" > "S-VIDEO" > "(composite) VIDEO" .
- When making COMPONENT VIDEO connections, connect "Y" to "Y", "Pb/Cb" to "Cb"(or "B-Y", "Pb") and "Pr/Cr" to "Cr"(or "R-Y", "Pr").
- When recording video program sources through VIDEO 1 OUT jacks or viewing ROOM 2 source through ROOM 2 OUT jacks, you must use the same type of video jacks that you did connect to video playback components such as DVD player, cable TV tuner, etc.

Video conversion

- This unit is equipped with a function that up-converts the video signals to the higher quality video signals and down-converts the video signals to the lower quality video signals and outputs them from the MONITOR OUTs.
- Depending on how to make video connections between this unit and video components, you should set the Monitor Output and the Video Mode correctly to output the video signals from the connected MONITOR OUT(s). (For details, refer to "When selecting the Monitor Output" on page 59 and "When selecting the Video Mode" on page 70.)
- Depending on each Monitor Output setting, the video signal flow is as follows :

■ When Monitor Output is set to HDMI

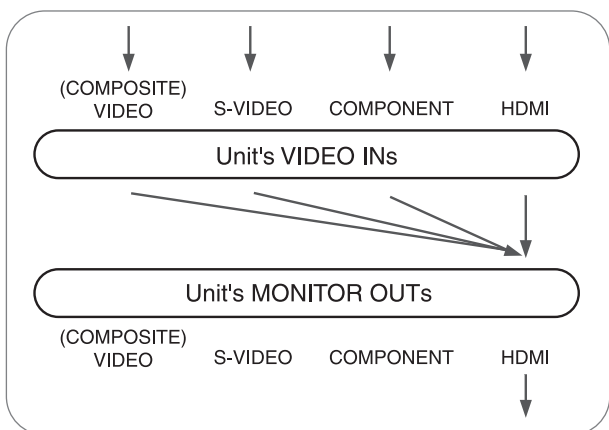

- The video signals are output from the HDMI MONITOR OUT only depending on the Video Mode setting.

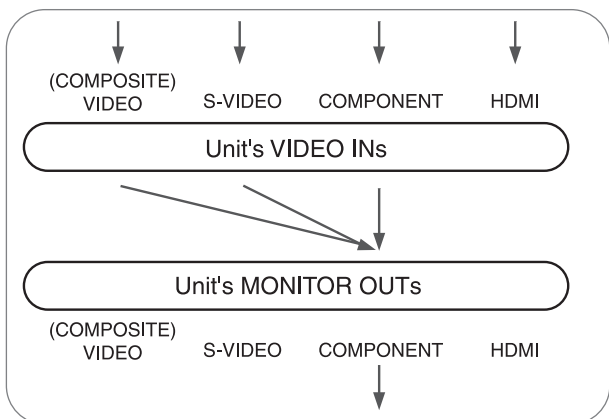

Continued**■ When Monitor Output is set to Component**

- The video signals are output from the COMPONENT MONITOR OUTs only depending on the Video Mode setting

■ Note :

- The HDMI video signals cannot be output regardless of the Video Mode setting.

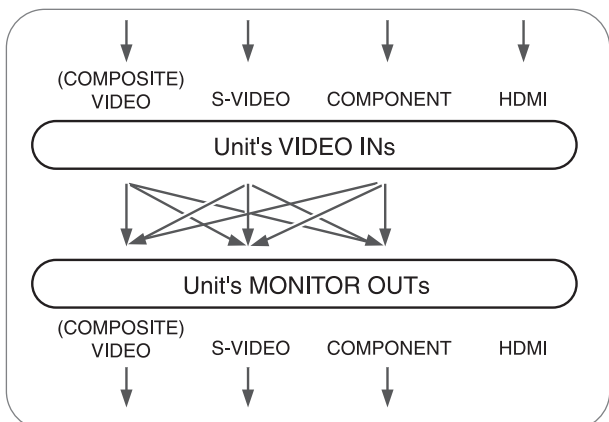
■ When Monitor Output is set to SC-Video

- The video signals are output from the (composite) VIDEO, the S-VIDEO and the COMPONENT MONITOR OUTs depending on the Video Mode setting.

■ Note :

- The HDMI video signals cannot be output regardless of the Video Mode setting.

Audio conversion

- When the HDMI Audio Output is set to On, this unit converts the analog audio signals (which are input into the (analog) AUDIO INs) or the digital audio signals (which are input into the HDMI IN, the OPTICAL or the COAXIAL DIGITAL IN) to the PCM 2 channel signals and outputs them from the HDMI MONITOR OUT depending on the Audio Mode setting. (For details, refer to "When selecting the HDMI Audio Output" on page 60 and "When selecting the Audio Mode" on page 71.)
- The digital audio signals (which are input into the OPTICAL or the COAXIAL DIGITAL IN) can be output from the OPTICAL DIGITAL OUT. However, the digital audio signals input into the HDMI IN cannot be output from the OPTICAL DIGITAL OUT.

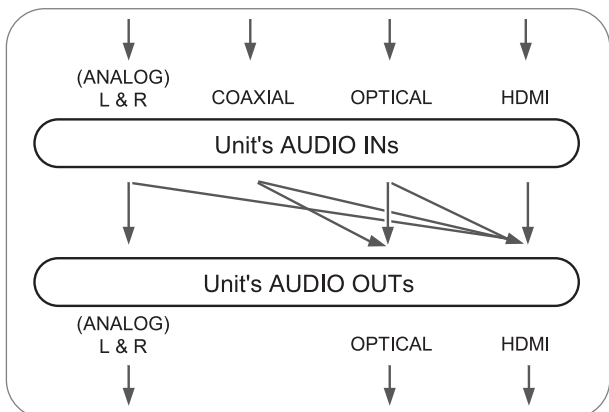
■ Audio Signal Flow**■ Note :**

- The audio signals which are input into the EXTERNAL INs or the USB cannot be output from any AUDIO OUTs.



3. CONNECTING AUDIO COMPONENTS

- The TAPE IN/OUT jacks can be connected to audio recording equipment such as a tape deck, an MD recorder, etc.

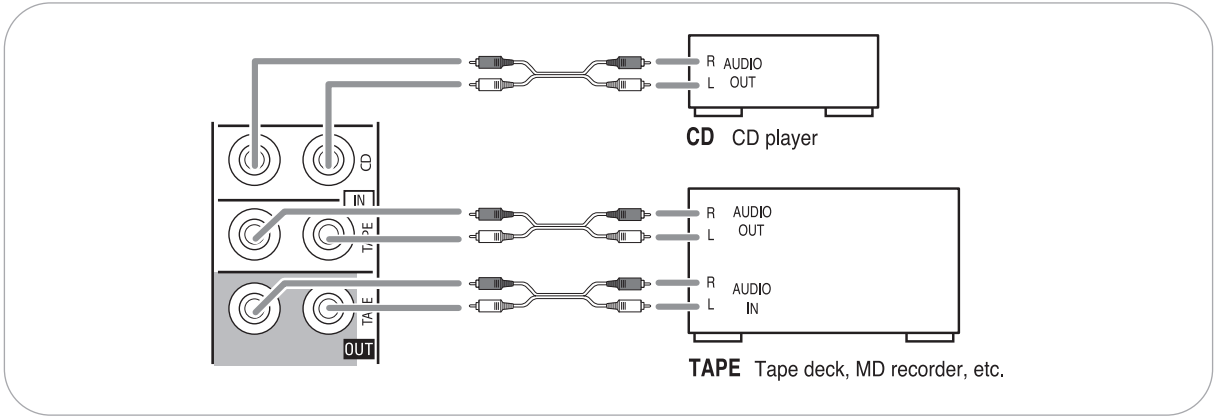

ENGLISH

4. CONNECTING EXTERNAL INs

- Use these jacks to connect the corresponding outputs of a DVD player or external decoder, etc. that has 6, 7 or 8 channel analog audio outputs.
- In case of 6 or 7 channel outputs, do not connect both of the SURROUND BACK L and R inputs or the SURROUND BACK R input of this unit. (For details, refer to the operating instructions of the component to be connected.)

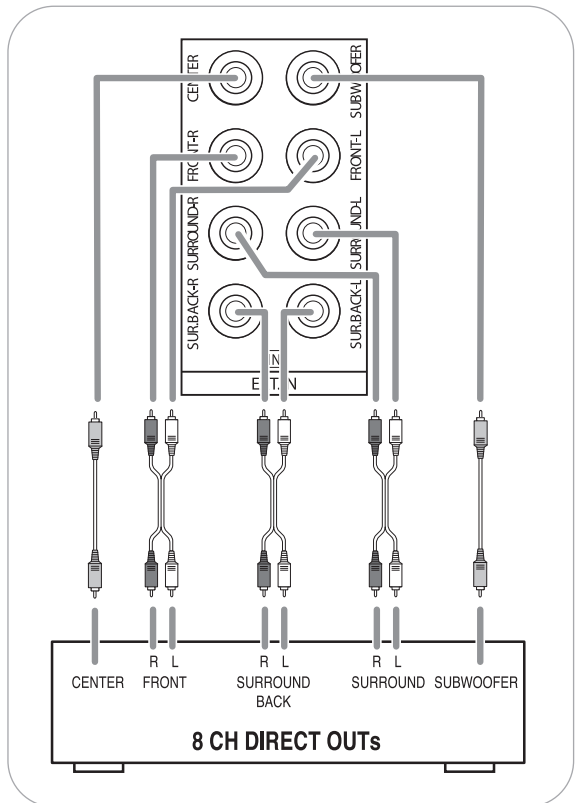

5. CONNECTING DIGITAL INS AND OUT

- The OPTICAL and the COAXIAL DIGITAL OUTS of the components that are connected to this unit can be connected to these DIGITAL INs.
- A digital input should be connected to the components such as a CD player, DVD player, etc. capable of outputting DTS Digital Surround, Dolby Digital or PCM format digital signals, etc.
- If the component with OPTICAL IN jack is connected to the OPTICAL OUT jack of this unit, you can record the high quality sound of CDs, etc. without degradation.
- For details, refer to the operating instructions of the component connected.
- When making the COAXIAL DIGITAL connection, be sure to use a 75 Ω COAXIAL cord, not a conventional AUDIO cord.
- Some of the commercially available optical fiber cords cannot be used for the equipment. If there is an optical fiber cord which cannot be connected to your equipment, consult your dealer or nearest service organization.

■ Notes :

- Be sure to make either a OPTICAL or a COAXIAL DIGITAL connection on each component. (You don't need to do both.)
- Depending on the digital audio signal format input into the HDMI IN connector, some digital signals cannot be output from the OPTICAL OUT jack.

■ Digital input default settings

- If you connect the DIGITAL INs to your components, it is easier to do so following the default settings.
- If your DIGITAL connections are different from default settings, you should assign the DIGITAL INs you used with the "When selecting the Audio Assign" procedure on page 70.
- The default settings are as follows :
OPTICAL IN 1:VIDEO 1, OPTICAL IN 2:VIDEO 2, OPTICAL IN 3:VIDEO 3, OPTICAL IN 4: VIDEO 4
(Front) OPTICAL IN 5: VIDEO 5, COAXIAL IN 1 : CD

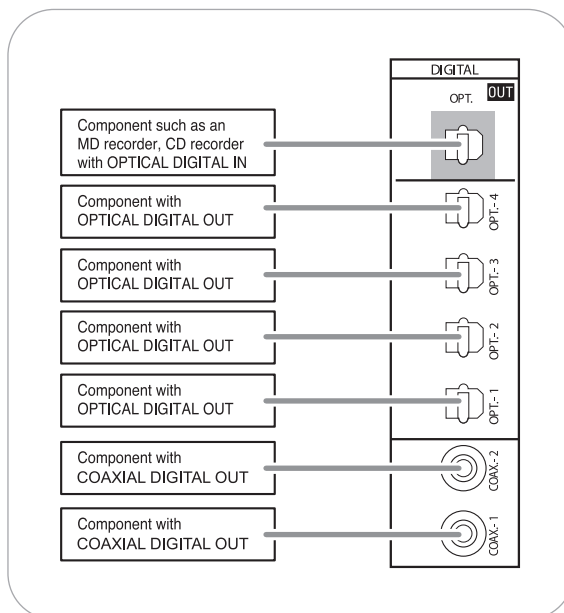

6. CONNECTING PRE OUTS

- Use these jacks when adding additional power amplifiers.
- Connect the PRE OUT jacks to the powered speakers or the power amplifiers connected to speakers respectively.
- When using only one surround back speaker, connect the SURROUND BACK LEFT jack to the power amplifier.
- To emphasize the deep bass sounds, connect a powered subwoofer.

■ Notes :

- After installing the speakers, first adjust the speaker settings according to your environment and speaker layout (For details, "SETTING THE SPEAKER/LISTENING SETUP" on page 61.)
- According to speaker settings, some channels of PRE OUTs cannot output audio signals.

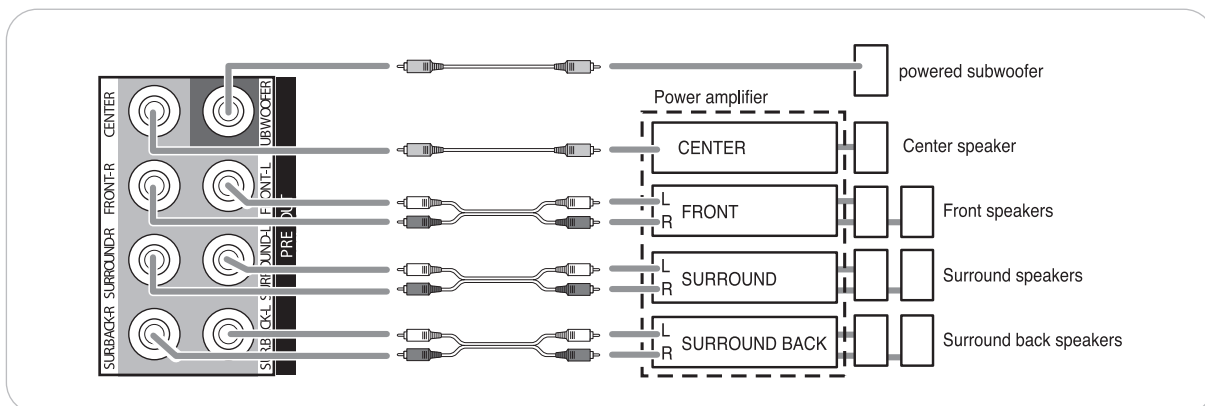



7. CONNECTING SPEAKERS

- Be sure to connect speakers firmly and correctly according to the channel(left and right) and the polarity (+ and -). If the connections are faulty, no sound will be heard from the speakers, and if the polarity of the speaker connection is incorrect, the sound will be unnatural and lack bass.
- For installing the speakers, refer to "Speaker placement" on page 12.
- After installing the speakers, first adjust the speaker settings according to your environment and speaker layout. (For details, refer to "SETTING THE SPEAKER /LISTENING SETUP" on page 61.)

■ Surround back speakers

- When using only one surround back speaker, you should connect it to SURROUND BACK/MULTI LEFT channel.
- Because this receiver cannot drive the surround back speakers and the ROOM 2 speakers simultaneously, you should assign their power amplifier correctly depending on how to use them. (For details, refer to "CONNECTING ROOM 2 AND ROOM 3 OUTS" on page 13 and "When selecting the AMP Assign" on page 58.)

■ Front Bi-Amp Connections.

- Some speakers are equipped with two sets of input terminals, for bi-amplification.
- If no other surround back speakers are used, you can connect the FRONT and the SURROUND BACK/MULTI channels to the bi-amp-capable speakers. (For details, refer to the operating instructions of your bi-amp-capable speakers.)
- To drive the bi-amp-capable speakers, you should assign the power amplifier to "BI-AMP".

■ Note :

- Before making bi-amp connections, remove the short-circuiting bars from the terminals of your speakers.

Caution :

- Be sure to use the speakers with the impedance of 6 ohms or above.
- Do not let the bare speaker wires touch each other or any metal part of this unit. This could damage this unit and/or the speakers.
- Never touch the speaker terminals while the AC input cord is connected to the wall AC outlet. Doing so could result in electric shocks.

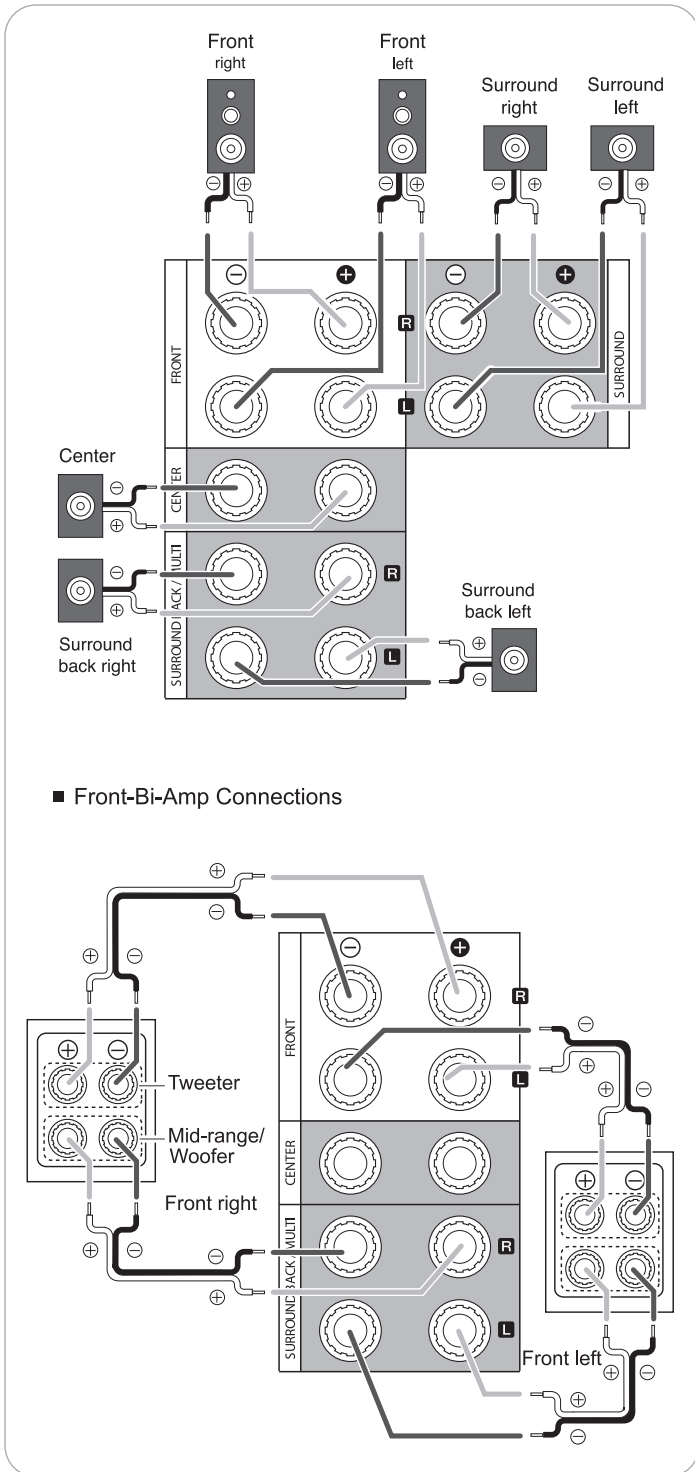

■ Front-Bi-Amp Connections

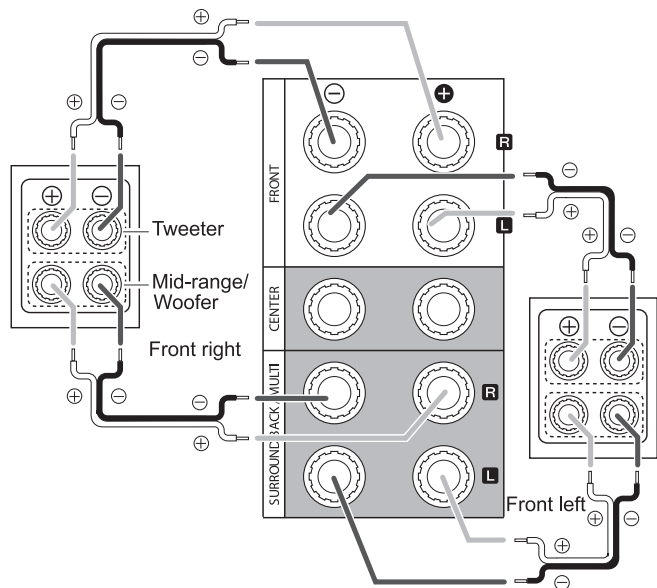



Continued

■ Connecting speaker wire

1. Strip away approx. 10 mm (3/8 inch) of wire insulation, then twist the wire ends tight.



2. Loosen by turning the speaker terminal counter-clockwise.



3. Insert the bare part of the wire.



4. Tighten by turning it clockwise.



ENGLISH

Speaker placement

Ideal speaker placement varies depending on the size of your room and the wall coverings, etc. The typical example of speaker placement and recommendations are as follows :

■ Front left and right speakers and center speaker

- Place the front speakers with their front surfaces as flush with TV or monitor screen as possible.
- Place the center speaker between the front left and right speakers and no further from the listening position than the front speakers.
- Place each speaker so that sound is aimed at the location of the listener's ears when at the main listening position.

■ Surround left and right speakers

- Place the surround speakers approximately 1 meter (40 inches) above the ear level of a seated listener on the direct left and right of them or slightly behind.

■ Surround back left and right speakers

- Place the surround back speakers at the back facing the front at a narrower distance than front speakers.
- When using a single surround back speaker, place it at the rear center facing the front at a slightly higher position (0 to 20 cm) than the surround speakers.
- We recommend installing the surround back speaker(s) at a slightly downward facing angle. This effectively prevents the surround back channel signals from reflecting off the TV or screen at the front center, resulting in interference and making the sense of movement from the front to the back less sharp.

■ Subwoofer

- The subwoofer reproduces powerful deep bass sounds. Place a subwoofer anywhere in the front as desired.

■ Notes :

- When using a conventional TV, to avoid interference with the TV picture, use only magnetically shielded front left and right and center speakers.
- To obtain the best surround effects, the speakers except the subwoofer should be full range speakers.

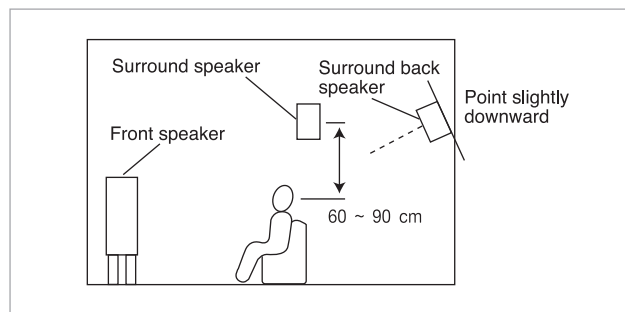
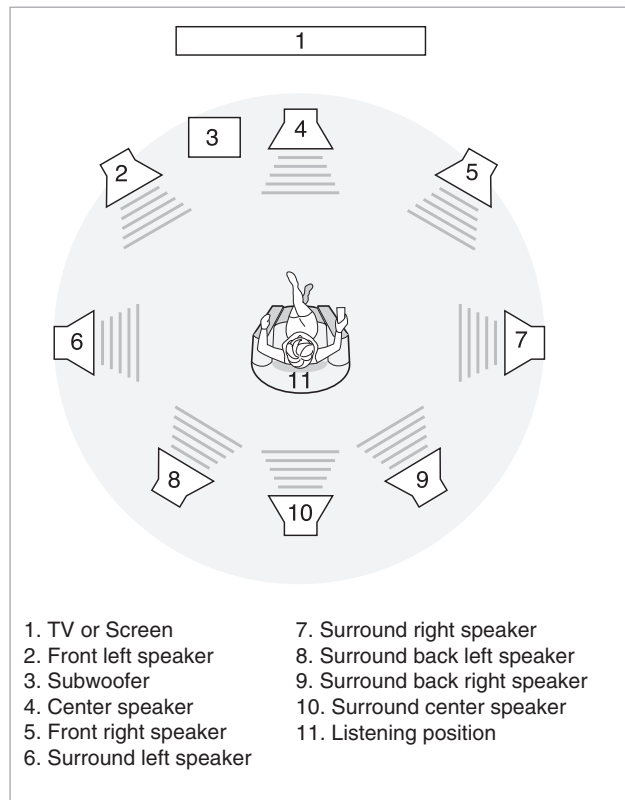



8. CONNECTING ROOM 2 AND ROOM 3 OUTS

- In addition to your main room, you can also enjoy playback in two other rooms (ROOM 2 and ROOM 3).

■ Connecting ROOM 2 OUTs

- You can select a different source for ROOM 2 and can play it.
- Depending on how to connect the ROOM 2 speakers, there are two ways as follows.
- In case of connecting the ROOM 2 speakers directly to this receiver, because this receiver cannot drive the surround back speakers and the ROOM 2 speakers simultaneously, you should assign their power amplifier correctly depending on how to use them. (For details, refer to "When selecting the AMP Assign" on page 58.)

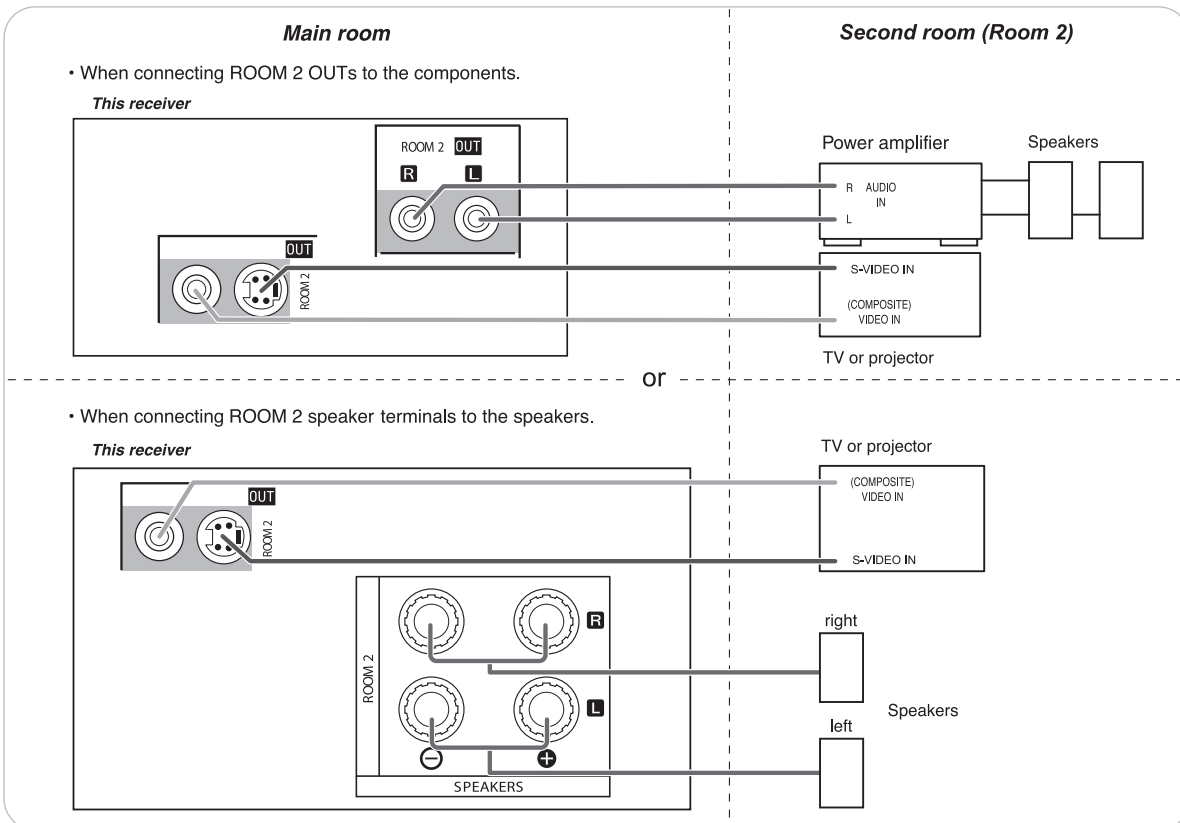

■ Connecting ROOM 3 OUTs

- You cannot select a different source for ROOM 3 and can play only the audio signals from the same source that you select for main room.

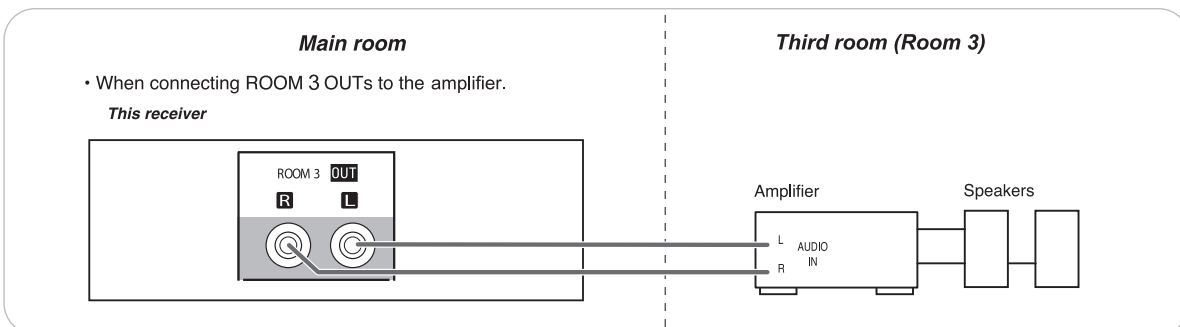

■ Notes :

- To minimize hum or noise, use high quality connection cords.
- You cannot use the digital audio signal for ROOM 2 and ROOM 3 playback.



9. CONNECTING XM (only for North America)

- Connect the XM terminal to the XM Mini-Tuner system (sold separately).
- Position the XM Mini-Tuner system near a south-facing window to receive the best signal.
When making connections, also refer to the operating instructions of the XM Mini-Tuner system.
- For the best reception, check the signal strength of the XM radio signal with using signal strength display mode, then adjust the position of the XM Mini-Tuner system until "SIGNAL : GOOD" is displayed. (For details, refer to "Displaying XM information" on page 47.)
- To listen to XM Satellite Radio, refer to "XM Satellite Radio (only for North America)" on page 45.

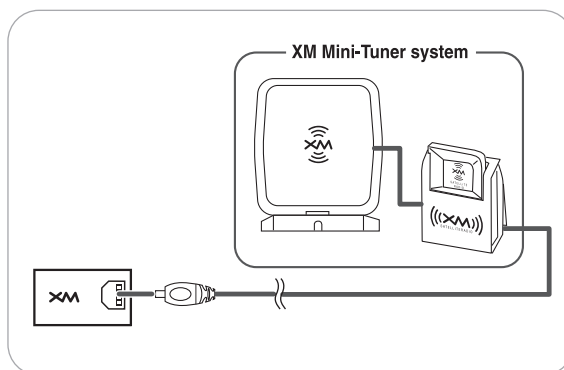

10. CONNECTING RF REMOTE ANTENNA

- Connect the supplied antenna to receive the RF (Radio Frequency) beams from the universal remote control.
- If the antenna is connected to this receiver, even though there are obstacles such as walls, furniture, etc. in the way, you can control this receiver with the universal remote control. Therefore, you can control this receiver from another room with the universal remote control without connecting the multi-room system kit. (For details, refer to "CONNECTING MULTI-ROOM SYSTEM KIT" on the next page.)

■Note:

- If the walls are too thick or the distance exceeds the operation range, you cannot control this receiver with the universal remote control. In such a case, connect the multi-room system kit to this receiver and set the transmission signal mode to "IR" (Infrared). (For details, refer to "Changing the transmission signal" on page 30.)

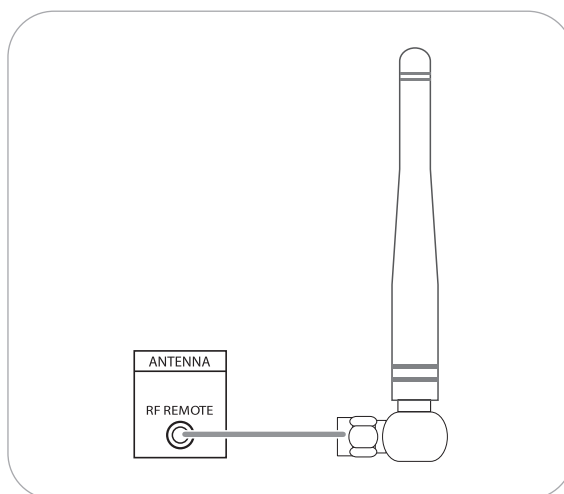

11. CONNECTING MICROPHONE

- To use Auto Setup function, connect the supplied microphone to the Trinnov Mic connector. (For details, refer to "When selecting the Auto Setup Trinnov Optimizer" on page 61.)

■Notes:

- Because the microphone for Auto Setup is especially designed by Trinnov for use with this receiver, do not use a microphone other than the one supplied with this receiver.
- After you have completed the auto setup procedure, disconnect the microphone.

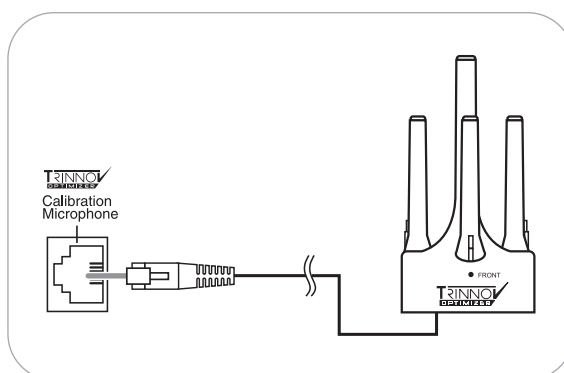



12. CONNECTING MULTI-ROOM SYSTEM KIT

- The multi-room system kit(sold separately) is essential for operation from a remote location .
For information on the multi-room system kit, contact the Xantech corporation at 1-800-843-5465 or www.xantech.com.
- IR IN jack allows you to control this receiver from other room(Room 2 and Room 3) with the remote control unit.
- To control this receiver from other room with the remote control unit, connect the IR IN jack to the output of the connecting block.
- If this receiver is located inside a cabinet or other enclosure where the signals from the remote control unit cannot enter, then operation with the remote control unit will not be possible. In such a case, connect the IR IN jack to the output of the connecting block.
- To control other compatible component from another room with the universal remote control unit, connect the IR OUT jack to the IR emitter.

■Notes :

- Remote operation may become unreliable if the IR receiver is exposed to strong light such as direct sunlight or inverted fluorescent.
- When the transmission signal mode is set to "RF", the IR receiver cannot accept the RF beams from the universal remote control and remote operation will become unreliable. However, because the IR emitter can emit the IR beams into which the RF beams are converted, you can control other compatible component via it.

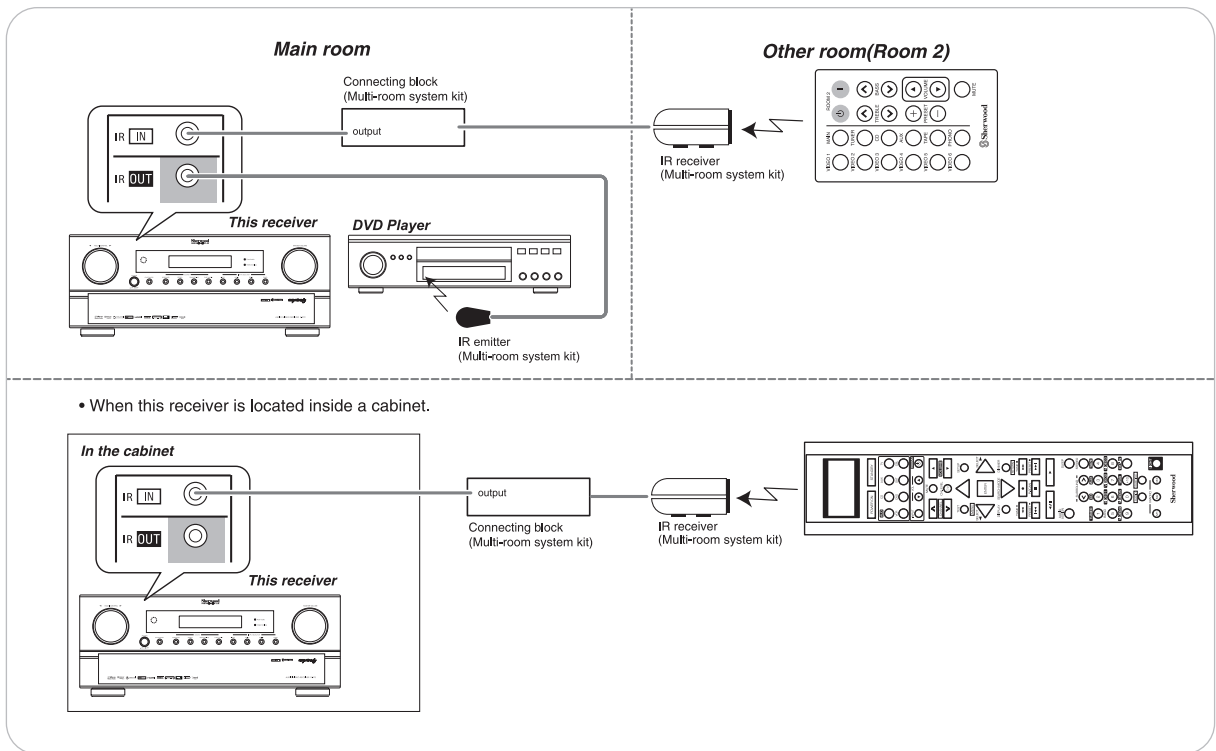

13. CONNECTING DC TRIGGER OUT

- Connect a component to DC TRIGGER OUT jack that allows DC 12V to turn on when a specific input source is selected.
- For details, refer to the operating instructions of the components to be connected.
- To link DC TRIGGER OUT with a specific input source, refer to "When selecting the DC Trigger" on page 72.

■Notes :

- This output voltage (12V d.c., 100mA) is for (status) control only, it is not sufficient for drive capability.
- When making DC TRIGGER connection, you should use the stereo mini cord, not a mono mini cord.

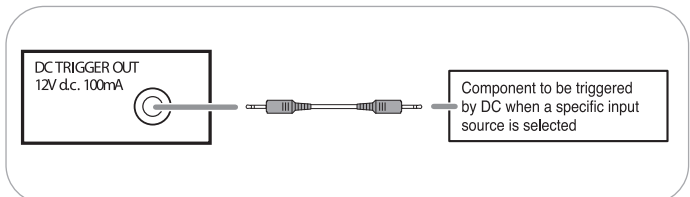

14. CONNECTING PC FOR UPGRADES

- This receiver incorporates RS-232C as well as USB terminal on the front panel that may be used in the future to update the operating software so that it will be able to support new digital audio formats, external control by using an external device and the like.
- Connect either RS-232C or USB terminal to your PC (you don't need to do both).

■Notes:

- Programming for upgrades and external control requires specialized programming knowledge and for that reason we recommend that it only be done by qualified installers. For more information on future upgrades and external control, visit the Sherwood web site at www.sherwoodamerica.com or contact your dealer.
- Do not disconnect the connection cable while updating the operating software, etc. Should this happen, it may be result in malfunction or cause damage to the unit.

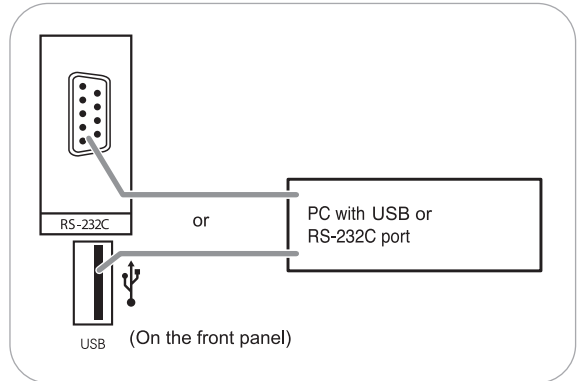

15. SWITCHED AC OUTLETS

- These outlets are switched on (power-on mode) and off (standby mode) according to power control as follows (Maximum total capacity is 120 W (1A)).

- Standby mode - Switched AC outlet off □
- Power-on mode - Switched AC outlet on □

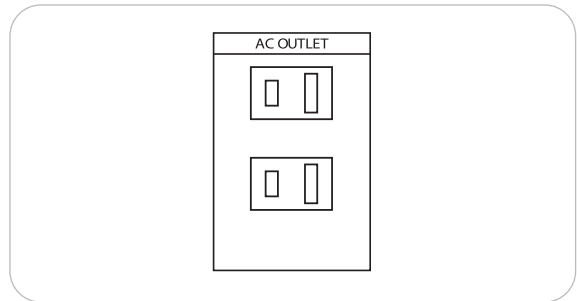

16. AC INPUT

- Plug the supplied AC input cord into this AC inlet and then into the wall AC outlet.

■Note:

- Do not use an AC input cord other than the one supplied with this unit. The AC input cord supplied is designed for use with this unit and should not be used with any other device.

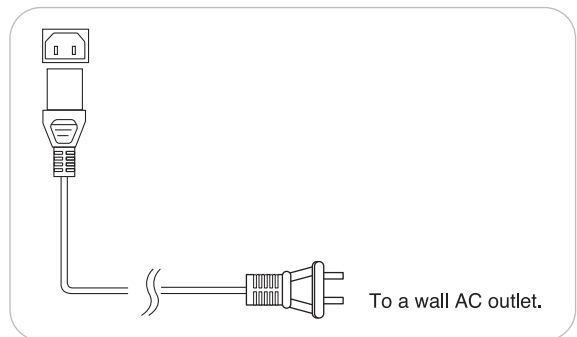

Front Panel Controls

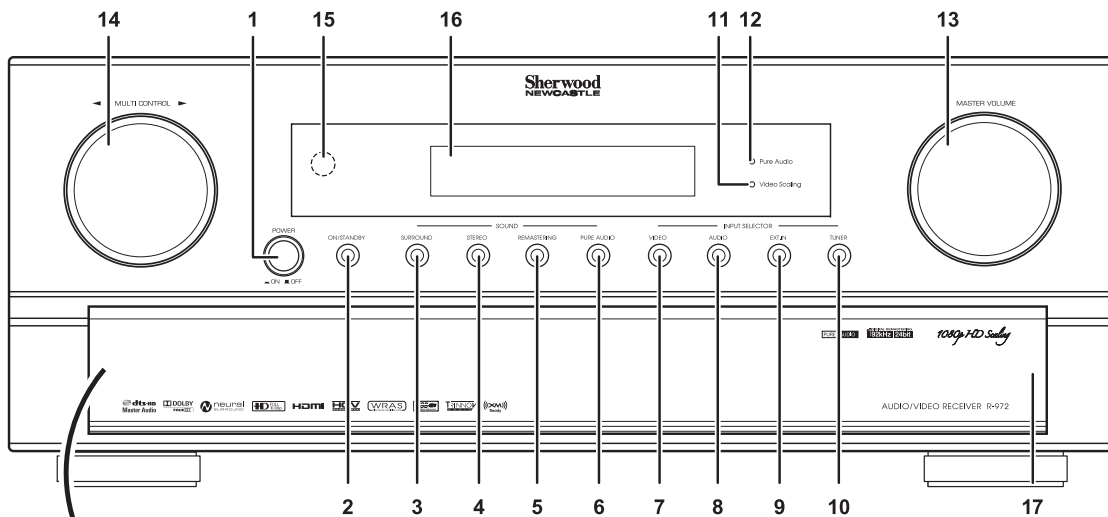

• To open the panel door, push gently on the lower third of the panel door.

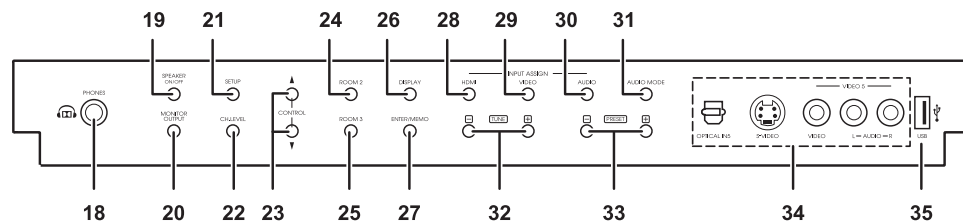

- | | |
|--------------------------------------|-----------------------------------|
| 1. POWER switch | 19. SPEAKER button |
| 2. POWER ON/STANDBY button/indicator | 20. MONITOR OUTPUT button |
| 3. SURROUND MODE button | 21. SETUP button |
| 4. STEREO button | 22. CHANNEL LEVEL button |
| 5. REMASTERING button | 23. CONTROL UP(▲)/DOWN(▼) buttons |
| 6. PURE AUDIO button | 24. ROOM 2 button |
| 7. VIDEO SELECTOR button | 25. ROOM 3 button |
| 8. AUDIO SELECTOR button | 26. DISPLAY button |
| 9. EXTERNAL IN button | 27. ENTER/MEMORY button |
| 10. TUNER button | 28. HDMI ASSIGN button. |
| 11. VIDEO SCALING indicator | 29. VIDEO ASSIGN button |
| 12. PURE AUDIO indicator | 30. AUDIO ASSIGN button |
| 13. MASTER VOLUME CONTROL knob | 31. AUDIO MODE button |
| 14. MULTI CONTROL knob | 32. TUNING UP(+)/DOWN(-) buttons |
| 15. REMOTE SENSOR | 33. PRESET UP(+)/DOWN(-) buttons |
| 16. FLUORESCENT DISPLAY | 34. VIDEO 5 IN jacks |
| For details, see next page. | For details, see next page. |
| 17. PANEL DOOR | 35. USB connector |
| 18. HEADPHONE jack | For details, see next page. |

ENGLISH



ENGLISH

FLUORESCENT DISPLAY

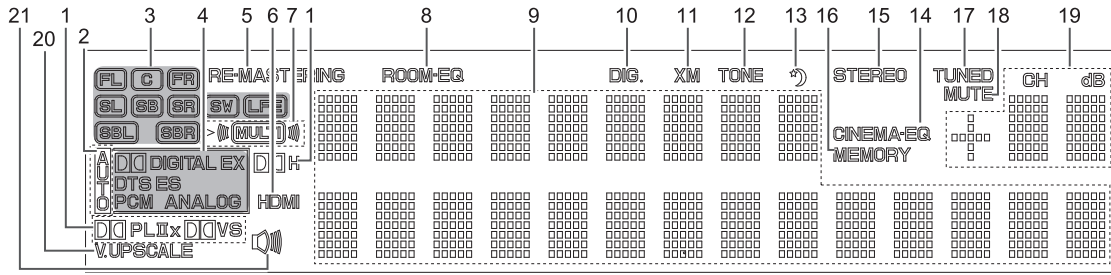

- | | |
|---|---|
| 1. Dolby surround mode indicators | 12. TONE indicator |
| 2. Auto surround indicator | 13. SLEEP indicator |
| 3. Speaker(/channel output : outer box) indicators | 14. CINEMA EQ indicator |
| 4. Input signal indicators | 15. STEREO indicator |
| 5. REMASTERING indicator | 16. MEMORY indicator |
| 6. HDMI indicator | 17. TUNED indicator |
| 7. ROOM 2 amp indicators | 18. MUTE indicator |
| 8. ROOM-EQ indicator | 19. Preset number, volume level, sleep time display |
| 9. Input, frequency, surround mode, operating information, etc. | 20. VIDEO UPSCALE indicator |
| 10. DIGITAL INPUT indicator | 21. SPEAKER indicator |
| 11. XM indicator | |

VIDEO 5 IN JACKS

- The VIDEO 5 input jacks may be also connected to an additional video component such as a camcorder, a video game player, etc.
- If the OPTICAL IN 5 is connected to the component connected to VIDEO 5, it is easier to do so following the default settings. (For details, refer to "Digital input default settings" on page 10.)
- If the OPTICAL IN 5 connection is different from the default settings, you should assign the DIGITAL INs you used with the "When selecting the Audio Assign" procedure on page 70.
- If you connect the COMPONENT VIDEO INs on the rear panel to your video component, you should assign the COMPONENT VIDEO INs you used with the "When selecting the Video Assign" procedure on page 70.
- If you connect the HDMI INs on the rear panel to your video component, you should assign the HDMI INs you used with the "When selecting the HDMI Assign" procedure on page 70.

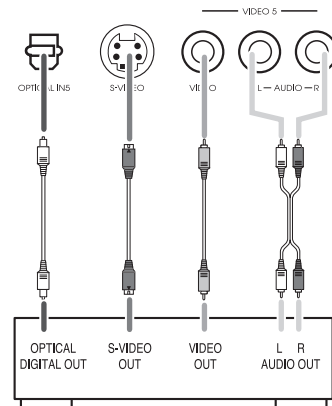

VIDEO 5 Camcorder, video game player, etc.

USB CONNECTOR

- This connector can be connected to a USB mass storage device directly to enjoy MP3 or WMA files stored on it through this receiver. (For details on the operation of USB device, refer to "PLAYING MUSIC FILES" on page 48.)

■ **Notes:**

- After USB playback, remove the USB device in the stop mode or the standby mode.
- You can connect this connector to PC for upgrades, too. (For details, refer to "CONNECTING PC FOR UPGRADES" on page 16.)

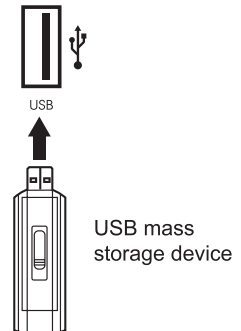

Universal Remote Controls

This universal remote control can operate not only this receiver but also most popular brands of audio and video components such as CD players, tape decks, TVs, cable boxes, VCRs, DVD players, satellite receivers, etc.

- To operate 7 components other than this receiver, you should enter the setup code for each component. (For details, refer to "USING FUNCTIONS OF REMOTE CONTROL" on page 22.)
- The numbered buttons on the remote control have different functions in different device modes. For details, refer to "FUNCTION TABLE of the NUMBERED BUTTONS" on the next page.

About the transmission signal

This remote control can emit not only the infrared beams which the conventional remote control (including the ROOM 2 remote control) uses but also the RF (Radio Frequency) beams which are stronger than those.

To operate this receiver and other components, this remote control should emit the infrared beams.

To operate this receiver only from longer distance even if there are obstacles such as walls, furniture, etc. in the way, this remote control should emit the RF beams.

Therefore, depending on how to use this remote control, you should set the transmission signal mode to "IR" (default value) or "RF". (For details, refer to "Changing the transmission signal" on page 30.)

Notes :

- To receive the RF beams, you should connect the RF remote antenna to this receiver. (For details, refer to "CONNECTING RF REMOTE ANTENNA" on page 14.)
- If the transmission signal mode is set to "RF", this remote control cannot control other audio and video components. However, if the IR emitter is connected to the IR OUT jack, you can control other component via it. (For details, refer to "CONNECTING MULTI-ROOM SYSTEM KIT" on page 15.)

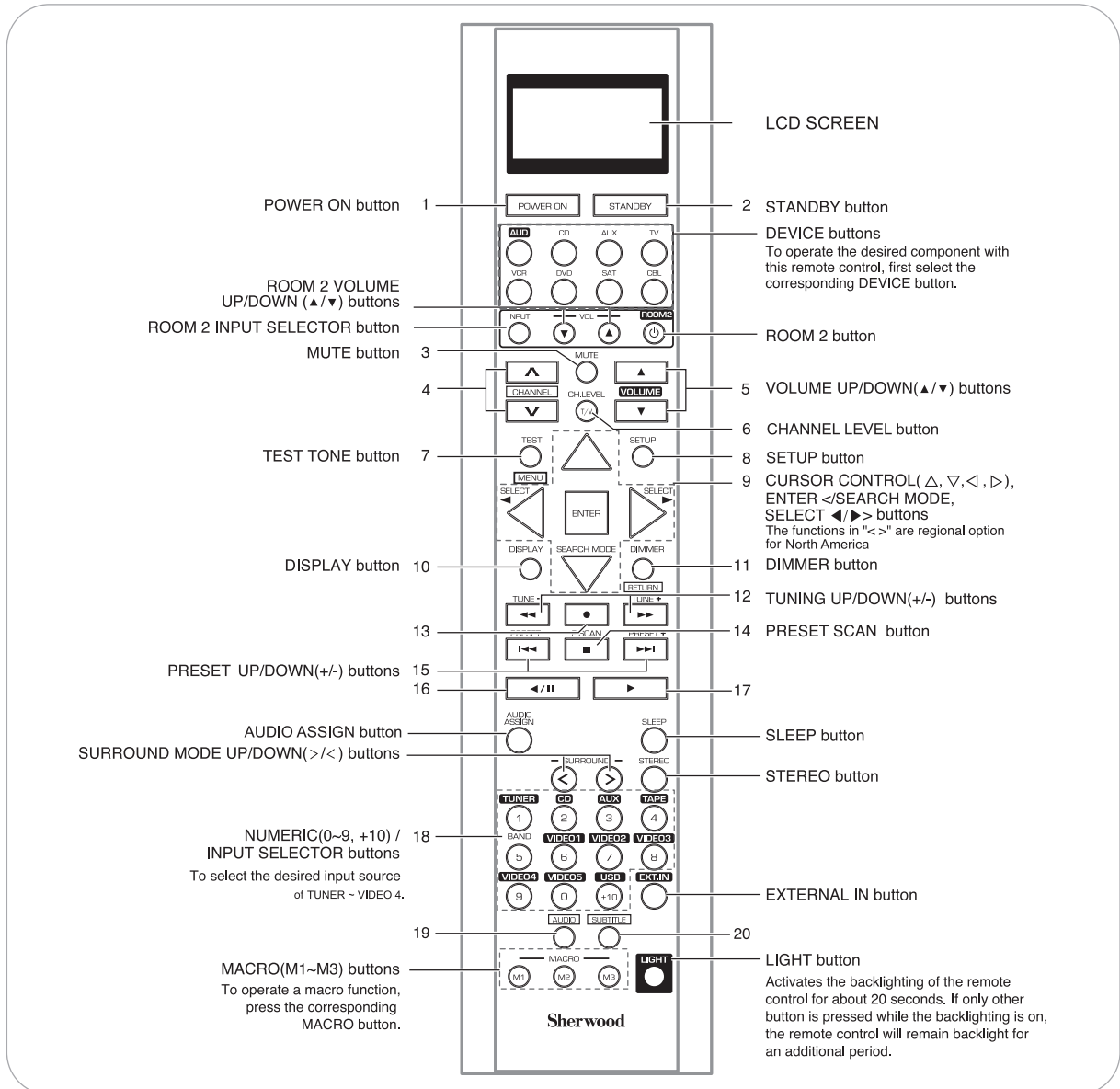



FUNCTION TABLE of the NUMBERED BUTTONS.

Device to be controlled	CD	AUX	TV	VCR	DVD	SAT	CBL
	(for CD player)	(for tape deck)	(for TV)	(for VCR)	(for DVD player)	(for satellite receiver)	(for cable box)
1	POWER ON	POWER ON	POWER ON	POWER ON	POWER ON	POWER ON	POWER ON
2	STANDBY (POWER OFF)	STANDBY (POWER OFF)	STANDBY (POWER OFF)	STANDBY (POWER OFF)	STANDBY (POWER OFF)	STANDBY (POWER OFF)	STANDBY (POWER OFF)
3	—	—	MUTE	MUTE	—	MUTE	MUTE
4	—	—	CHANNEL UP/DOWN(▲/▼)	CHANNEL UP/DOWN(▲/▼)	—	CHANNEL UP/DOWN(▲/▼)	CHANNEL UP/DOWN(▲/▼)
5	—	—	VOLUME UP/DOWN(▲/▼)	VOLUME UP/DOWN(▲/▼)	—	VOLUME UP/DOWN(▲/▼)	VOLUME UP/DOWN(▲/▼)
6	—	—	INPUT SELECTOR	INPUT SELECTOR	—	INPUT SELECTOR	INPUT SELECTOR
7	—	—	—	—	MENU	—	—
8	—	—	—	—	SETUP	—	—
9	—	—	—	—	CURSOR CONTROL	—	—
	—	—	—	—	ENTER	—	—
10	—	—	—	—	DISPLAY	—	—
11	—	—	—	—	RETURN	—	—
12	REVERSE SEARCH(◀◀) / FORWARD SEARCH(▶▶)	REWIND(◀◀) / FAST FORWARD(▶▶)	—	REWIND(◀◀) / FAST FORWARD(▶▶)	REVERSE SEARCH(◀◀) / FORWARD SEARCH(▶▶)	—	—
13	—	RECORD	—	RECORD	—	—	—
14	STOP	STOP	—	STOP	STOP	—	—
15	REVERSE SKIP(◀◀) / FORWARD SKIP(▶▶)	—	—	—	REVERSE SKIP(◀◀) / FORWARD SKIP(▶▶)	—	—
16	PAUSE	REVERSE PLAY	—	PAUSE	PAUSE	—	—
17	PLAY	FORWARD PLAY	—	PLAY	PLAY	—	—
18	NUMERIC	—	NUMERIC	NUMERIC	NUMERIC	NUMERIC	NUMERIC
19	—	—	—	—	AUDIO	—	—
20	—	—	—	—	SUBTITLE	—	—

Notes :

- Some functions for each component may not be available or may work differently.
- Depending on other kinds of components that are available for each DEVICE button, some functions may not be available or may work differently, too.
- For details about functions, refer to the operating instructions of each component.



OPERATING COMPONENTS WITH REMOTE CONTROL

1. Enter the setup code for each component other than this receiver. For details, refer to "Entering a setup code" on page 22.
2. Turn on the component you want to operate.
3. Press the DEVICE button on the remote control corresponding to the component you wish to operate.
4. Aim the remote control at the REMOTE SENSOR of the component you wish to control and press the button corresponding to the operation you want.

■ Notes :

- When you cannot operate any component, check if the transmission signal mode is set to "RF". (For details, refer to "Changing the transmission signal" on page 30.)
- In this case, to operate the component, connect the IR emitter to the IR OUT jack and use the remote control toward this receiver. (For details, refer to "CONNECTING RF REMOTE ANTENNA" on page 14 and "CONNECTING MULTI-ROOM SYSTEM KIT" on page 15.)

LOADING BATTERIES

- When the remote control does not operate, the old batteries should be replaced. In this case, load new batteries within several minutes after removing old batteries.
- If the batteries are removed or have been exhausted for a longer period of time, memorized contents will be cleared. Should this happen, you should memorize them again.

1. Remove the cover.

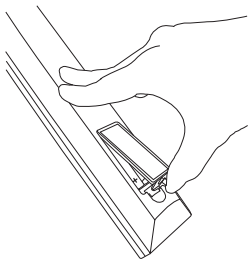

REMOTE CONTROL OPERATION RANGE

- In case that this remote control emits the infrared beams
 - Use the remote control within a range of about 7 meters (23 feet) and angles of up to 30 degrees aiming at the remote sensor.

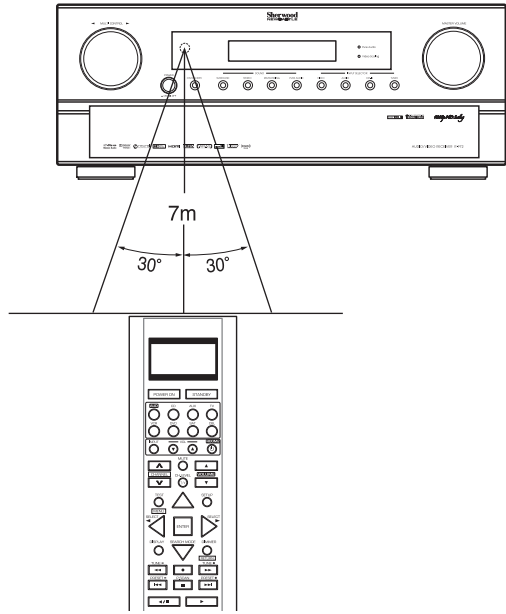

- In case that this remote control emits the RF beams
 - Use the remote control within a distance of about 15 meters (50 feet) toward this receiver.

2. Load four alkaline batteries ("AAA" size, 1.5V) matching the polarity.

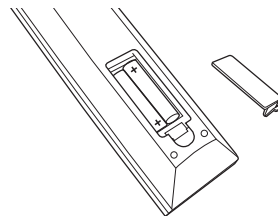

- Remove the batteries when they are not used for a long time.
- Do not use the rechargeable batteries (Ni-Cd type).
- Be sure to use alkaline batteries.

USING FUNCTIONS OF REMOTE CONTROL

- This remote control can control up to 8 different components.
- Before operating audio and video components other than this receiver with using this remote control, the setup code for each component should be entered.
- For system remote control operation, "000" was stored previously in the memory of the device button "CD" for Sherwood CD player, "DVD" for Sherwood DVD player, "AUX" for Sherwood tape deck and "TV" for Sherwood TV respectively as its factory setup code. So, you don't need to enter its code for each Sherwood component except in such a case that its code does not work.

■ Note :

- If the transmission signal which this remote control emits is changed into "RF"(Radio Frequency), this remote control cannot control other audio and video components. (For details, refer to "Changing the transmission signal" on page 30.)

Entering a setup code

- Setup code entry is the easiest way to program this remote control for operating audio and video components.

1. Turn on the component you want to operate.

2. Find the setup codes according to the type and the brand name of your component, referring to "Setup Code Table" on page 85.

3. Press and hold down both the ENTER button and the desired one of the DEVICE buttons for more than 2 seconds.

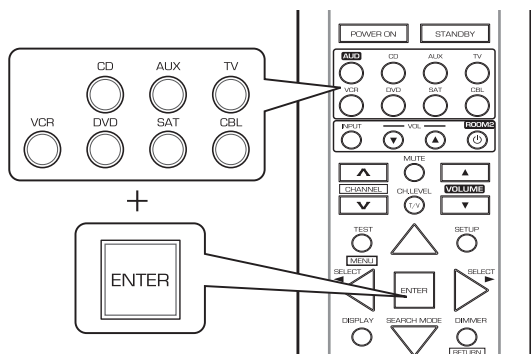

- Then "LEARN" is displayed on the LCD screen for several seconds.

■ Notes :

- The AUDIO button is unavailable for the audio components other than this receiver.
- During setting operation, to exit from the setting mode, press any of the DEVICE buttons.

4. While "LEARN" is displayed, press the CURSOR UP(▲)/DOWN(▼) buttons to select the setup code mode ("CODE"), then press the ENTER button.

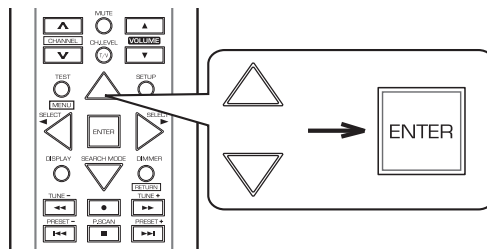

- Each time the CURSOR UP(▲)/DOWN(▼) buttons are pressed, the mode changes as follows :

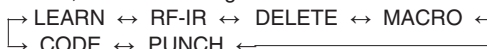

- Then "PRESET" and 3 digit number are displayed.
- If "PRESET", etc. go off, start again from the above step 3.

5. While "PRESET", etc. are displayed, enter a 3 digit code and press the ENTER button.

Example: When entering "001".

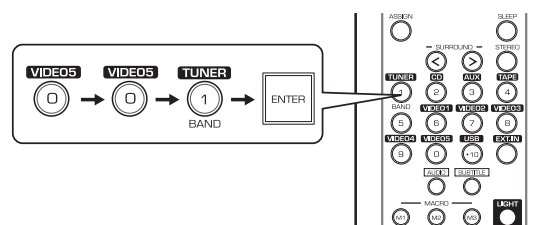

- Then "OK" is displayed on the LCD screen.
- To be sure that the setup code is correct, press the POWER ON (or STANDBY) button, aiming the remote sensor on the component.
- If the setup code is correct, your component will be turned off.
- When your component is not turned off, repeat the above steps 2 to 5, trying entering each code for your component until you find one that works.
- If "NG" is displayed, retry entering the correct setup code while "PRESET" and 3 digit number are displayed.

6. Operate the component using the corresponding function buttons.

- If any of buttons fails to operate as they should, start from the step 1 again to enter the correct setup code.

■ Note :

- Manufacturers may use different setup codes for the same product category. For that reason, it is important that you check to see if the code you have entered operates as many controls as possible. If only a few functions operate, check to see if another code will work with more buttons.

7. Repeat the above steps 1 to 6 for each of your other components.

Searching a setup code

- In addition to enter a setup code using "Setup Code Table" on page 85, it is also possible to search through all the codes that are stored in the library of this remote control.

1. Turn on the component you want to operate.

2. Perform the steps 3 and 4 in "Entering a setup code" procedure on page 22 to select the setup code mode ("CODE").

3. While "PRESET" is displayed, search a setup code, aiming the remote control at the remote sensor on the component.

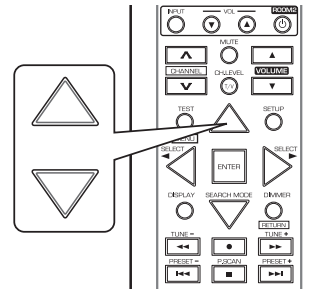

- Each time the CURSOR UP(▲)/DOWN(▼) buttons are pressed, the setup code is selected one by one.
- If the selected code is correct, your component will be turned off.
- When your component is not turned off, repeat this step until you find one that works.

4. While "PRESET" is displayed, press the ENTER button to store the setup code.

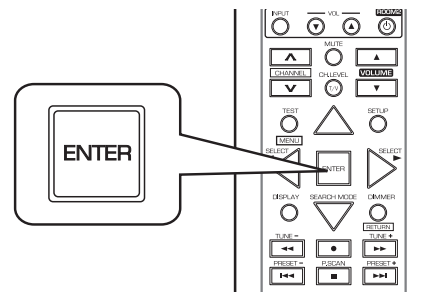

- Then "OK" is displayed on the LCD screen.

5. Operate the component using the corresponding function buttons.

- If any of buttons fails to operate as they should, start from the step 1 again to find the correct setup code.

6. Repeat the above steps 1 to 5 for each of your other components.

Programming the commands from other remote controls (LEARNING mode)

- If the setup codes are not available for your component or you want to program a missing or special function into one button of a device, the learning function enables this remote control to learn the commands from other remote controls.

1. Place this remote control and other remote control facing each other at a distance of 5 to 15 cm (2 to 6 inches) apart.

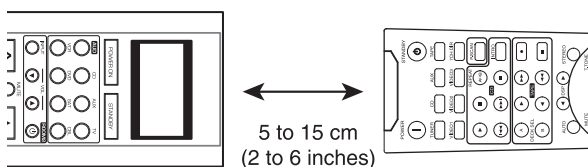

2. Press and hold down the ENTER button and the desired one of the DEVICE buttons for more than 2 seconds.

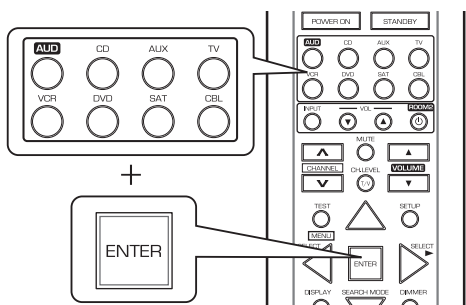

- Then "LEARN" is displayed on the LCD screen for several seconds

Note :

- During setting operation, to exit from the setting mode, press any of the DEVICE buttons.

3. While "LEARN" is displayed, press the ENTER button.

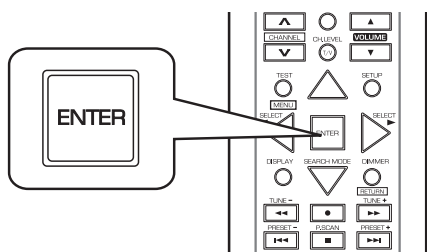

- Then "SEL" is flickering.
- If "SEL" goes off, start again from the above step 2.

4. While "SEL" is flickering, on this remote control, press the button corresponding to the function to be learned.

Example: If the function to be learned is playback, press the PLAY (▶) button.

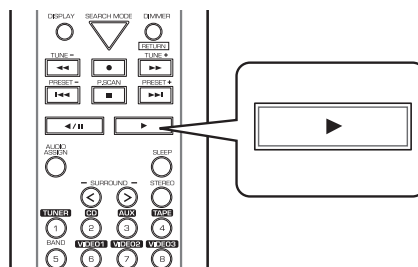

- Then "READY" is displayed.

Note:

- You cannot program a function into some buttons such as DEVICE, MACRO and LIGHT buttons.

5. While "READY" is displayed, on the other remote control, press the button of the function to be learned.

- If the command has been learned successfully, "OK" is displayed and then "SEL" is flickering.
- If "ERROR" is displayed and then "SEL" is flickering, it means that for some reason the command was not learned. In this case, repeat the above steps 4 and 5.

Notes :

- If an incorrect signal has been sent or, in some cases, the command from other remote control simply cannot be learned.
- In some "ERROR" cases, the remote controls just need to be moved closer together or farther apart.

6. While "SEL" is flickering, repeat the above steps 4 and 5 to program all the commands you want to the buttons on this remote control under the same device mode.

- To exit from the setting mode, press any of the DEVICE buttons.

7. Repeat the above steps 1 to 6 to program the commands from a different remote control.

8. Operate the newly programmed buttons to make sure the learning function was performed properly.



Erasing the programmed command from one button

1. Perform the steps 3 and 4 in "Entering a setup code" procedure on page 22 to select the deleting mode ("DELETE").
 - Then "BTTN" is displayed on the LCD screen for several seconds.
2. While "BTTN" is displayed, press the CURSOR UP(▲)/DOWN(▼) buttons to select the one command deleting mode (BTTN), then press the ENTER button.

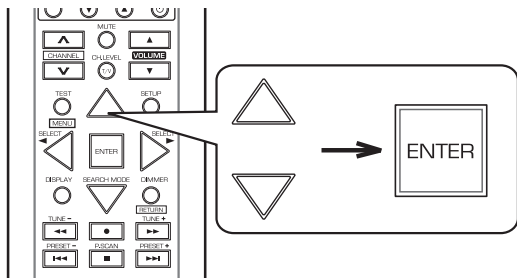

- Each time the CURSOR UP(▲)/DOWN(▼) buttons are pressed, "BTTN" or "LEARN"(all command deleting mode) is selected.
- Then "SEL" is flickering.
- If "SEL" goes off, start again from the above step 1.

3. While "SEL" is flickering, press the button for the command you want to erase.

Example: When the button for the command to be erased is PLAY button.

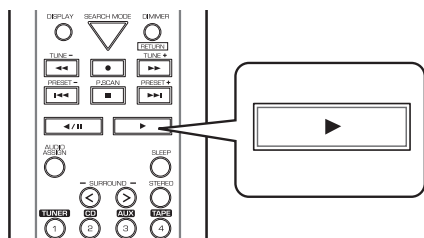

- "OK" is displayed and then "SEL" is flickering.

4. While "SEL" is flickering, repeat the above step 3 to erase other commands.

Erasing all the commands programmed under a device mode

1. Perform the steps 3 and 4 in "Entering a setup code" procedure on page 22 to select the deleting mode ("DELETE").
 - Then "BTTN" is displayed on the LCD screen for several seconds.
2. While "BTTN" is displayed, press the CURSOR UP(▲)/DOWN(▼) buttons to select the all command deleting mode ("LEARN"), then press the ENTER button.

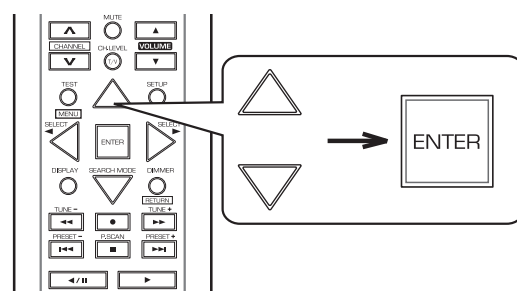

- Then "SURE?" is displayed .
- If "SURE?" goes off, start again from the above step 1.

3. While "SURE?" is displayed, press the ENTER button.

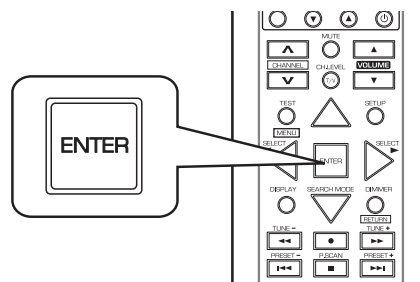

- Then all the commands programmed are erased.

4. To erase all the commands programmed under other device mode, repeat the above steps 1 to 3.



Programming a macro function

- The macro function enables you to program a series of button operations (up to 15) on this remote control into a single button.
- You can store up to three separate macro command sequences into "M1", "M2" and "M3" buttons.

1. Perform the steps 3 and 4 in "Entering a setup code" procedure on page 22 to select the macro mode ("MACRO").

- Then "M1" is displayed on the LCD screen for several seconds.
- During macro setting operation, pressing any of the DEVICE buttons cannot exit from the macro mode.

2. While "M1" is displayed, press the CURSOR UP(▲)/DOWN(▼) buttons to select the MACRO button to be programmed into, then press the ENTER button.

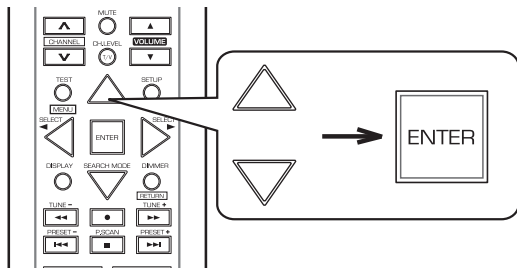

- Each time the CURSOR UP(▲)/DOWN(▼) buttons are pressed, "M1", "M2" or "M3" is selected.
- Then "SEL" is flickering.
- If "SEL" goes off, start again from the above step 1.

3. While "SEL" is flickering, press the operation buttons you want to program in order.

Example: When playing a DVD on the DVD player connected to VIDEO 2 jacks of this receiver.

- ①. Press "AUDIO" button to control this receiver.
- ②. Press "POWER ON" button to turn this receiver on.
- ③. Press "VIDEO 2(7)" button to select the desired input source.
- ④. Press "DVD" button to control the DVD player.
- ⑤. Press "POWER ON" button to turn the DVD player on.
- ⑥. Press "PLAY (▶)" button to start playback.



- Each time the operation buttons are pressed, the programmed order is displayed.

4. Press any of the MACRO buttons (M1-M3) to complete the programming.

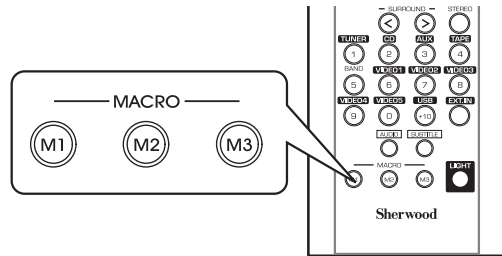

- Then "OK" is displayed.

■ To erase a macro program

- When erasing a macro program, perform the above steps 1, 2 and 4, but ignore the step 3.

■ To change a macro program

- When a new macro program is stored into a MACRO button with performing the above steps 1 to 4, the previous macro program is erased from the memory of the MACRO button.

Operating a macro function

- Aim the remote control at the REMOTE SENSORS of the components to be controlled and press the MACRO button you want.
Example : When pressing "M1" button.

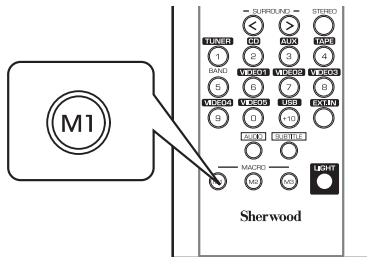

Notes:

- The codes programmed into a MACRO button will be transmitted at an interval of 0.5 seconds. However, some components may not be able to complete one operation in 0.5 seconds and may miss the next code. In this case, the macro function cannot control the corresponding components correctly.
- Be sure to use the remote control within the remote control operation range of the components.
- Depending on the operation status of the components, etc., the macro function cannot control the corresponding components correctly.

Programming a punch-through function

- The punch-through function allows the volume controls, channel controls or transport controls to link to a different device while a device is controlled with this remote control as a master device.
- For example, since this receiver will likely be used as the sound system while watching TV, you may want to use volume controls to operate this receiver although this remote control is set to control the TV.

1. Perform the steps 3 and 4 in "Entering a setup code" procedure on page 22 to select a master device and the punch-through mode ("PUNCH").

- Then "VOL" is displayed on the LCD screen for several seconds.

2. While "VOL" is displayed, press the CURSOR UP(▲)/DOWN(▼) buttons to select the desired punch-through mode, then press the ENTER button.

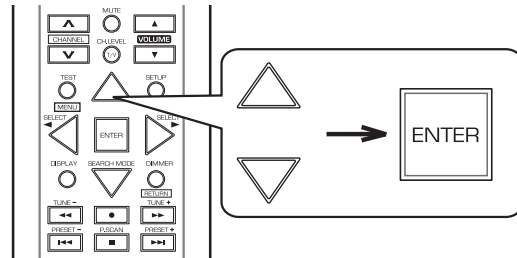

- Each time the CURSOR UP(▲)/DOWN(▼) buttons are pressed, the mode changes as follows:
 - VOL : The volume punch-through mode allows the "VOLUME ▲/▼" and "MUTE" buttons to operate a different device.
 - ↕
 - DELETE : All punch-through deleting mode.
 - ↕
 - PLAY : The transport punch-through mode allows the "◀", "●", "▶", "◀◀", "■", "▶▶", "◀/||" and "▶" buttons to operate a different device.
 - ↕
 - CH : The channel punch-through mode allows the "CHANNEL ^ / v" and "CH. LEVEL" buttons to operate a different device.
- Then the device to which you can link the selected punch-through mode is displayed.

Continued

- 3.** While the device is displayed, press the CURSOR UP(▲)/DOWN(▼) buttons to select the desired punch-through device, then press the ENTER button.

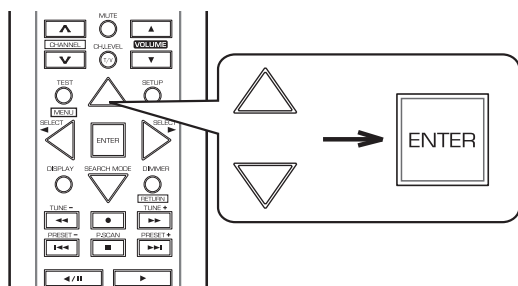

- Each time the CURSOR UP(▲)/DOWN(▼) buttons are pressed, depending on the selected punch-through mode, punch-through devices and the one punch-through deleting mode ("DELETE") are selected as follows :

- In case of the volume punch-through,
→ AUDIO ↔ DELETE ↔ TV ←
- In case of the transport punch-through,
→ CD ↔ DELETE ↔ DVD ↔ VCR ↔ AUX ←
- In case of the channel punch-through,
→ TV ↔ DELETE ↔ SAT ↔ CABLE ↔ VCR ←
- Then "OK" is displayed and the current punch-through mode is displayed.

- 4.** While the punch-through mode is displayed, repeat the above steps 2 and 3 to program other punch-through function under the same master device mode.

- 5.** To program punch-through functions under other master device mode, repeat the above steps 1 to 4.

Operating a punch-through function

- While this remote control is set to control a master device, aim the remote control at the REMOTE SENSOR of the punch-through device and press the desired button of the programmed punch-through controls.

Example: When pressing "PLAY (▶)" button.

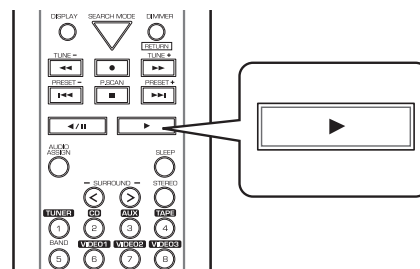

- Then the punch-through device is displayed on the LCD screen.

Erasing the programmed punch-through function

- 1.** Perform the steps 3 and 4 in "Entering a setup code" procedure on page 22 to select a master device and the punch-through mode ("PUNCH").

- Then "VOL" is displayed on the LCD screen for several seconds.

- 2.** While "VOL" is displayed, press the CURSOR UP(▲)/DOWN(▼) buttons to select the punch-through mode to be erased, then press the ENTER button.

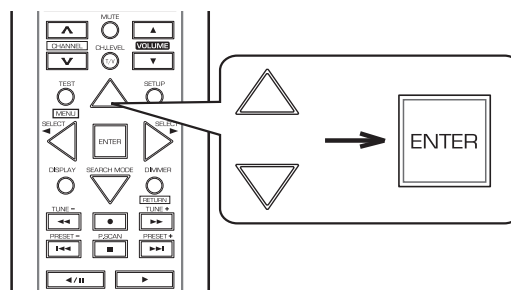

- Each time the CURSOR UP(▲)/DOWN(▼) buttons are pressed, the mode changes as follows:

→ VOL ↔ DELETE ↔ PLAY ↔ CH ←

- Then the device is displayed .



Continued

- While the device is displayed, press the CURSOR UP(▲)/DOWN(▼) buttons to select the one punch-through deleting mode ("DELETE"), then press the ENTER button.

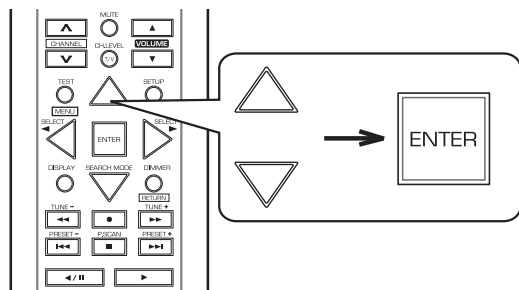

- Each time the CURSOR UP(▲)/DOWN(▼) buttons are pressed, depending on the selected punch-through mode, the punch-through devices and the deleting mode ("DELETE") are selected.
- Then "OK" is displayed and the current punch-through mode is displayed .

- While the punch-through mode is displayed, repeat the above steps 2 and 3 to erase other punch-through function under the same master device mode.

- To erase punch-through functions under other master device mode, repeat the above steps 1 to 4.

Erasing all the punch-through functions programmed under a master device mode

- Perform the steps 3 and 4 in "Entering a setup code" procedure on page 22 to select a master device and the punch-through mode ("PUNCH").

- Then "VOL" is displayed on the LCD screen for several seconds.

- While "VOL" is displayed, press the CURSOR UP(▲)/DOWN(▼) buttons to select the all punch-through deleting mode ("DELETE").

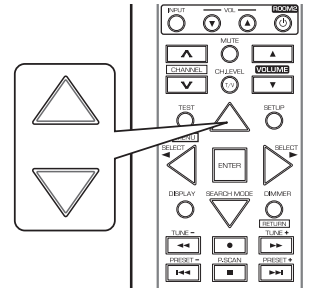

- Each time the CURSOR UP(▲)/DOWN(▼) buttons are pressed, the mode changes as follows:



- Then "DELETE" is displayed .

- While "DELETE" is displayed, to erase all the punch-through functions programmed under the master device mode, press ENTER button.

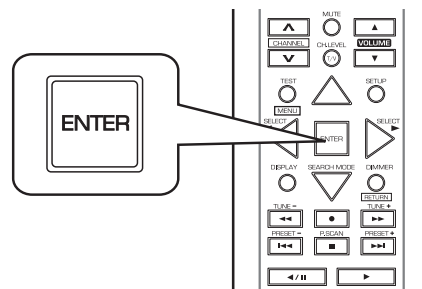

- Then "OK" is displayed and "DELETE" is displayed.
- To exit from the deleting mode, press any of the DEVICE buttons.

- To erase all the punch-through functions programmed under other master device mode, repeat the above steps 1 to 3.



Changing the transmission signal

- This remote control can emit not only the infrared beams which the conventional remote control uses but also the RF(Radio Frequency) beams which are stronger than those.
- When you want to control this receiver from longer distance even if there are obstacles such as walls, furniture, etc. in the way, change the transmission signal into "RF"(Radio Frequency).

■ Notes:

- When the RF remote antenna is not connected, remote operation will become unreliable. (For details, refer to "CONNECTING RF REMOTE ANTENNA" on page 14.)
- If the transmission signal mode is set to "RF" (Radio Frequency), this remote control cannot control other audio and video components.
- In this case, to control the component, connect the IR emitter to the IR OUT jack. (For details, refer to "CONNECTING MULTI-ROOM SYSTEM KIT" on page 15.)

1. Press and hold down the ENTER button and the AUDIO button for more than 2 seconds.

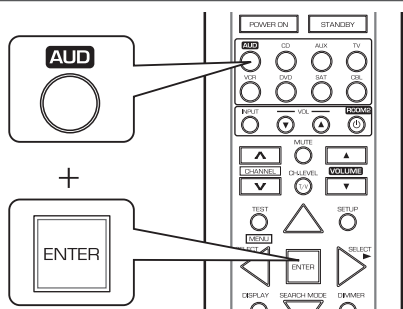

- Then "LEARN" is displayed on the LCD screen for several seconds.

■ Note:

- During setting operation, to exit from the setting mode, press any of the DEVICE buttons.

2. While "LEARN" is displayed, press the CURSOR UP(▲)/DOWN(▼) buttons to select the transmission signal mode("RF-IR"), then press the ENTER button.

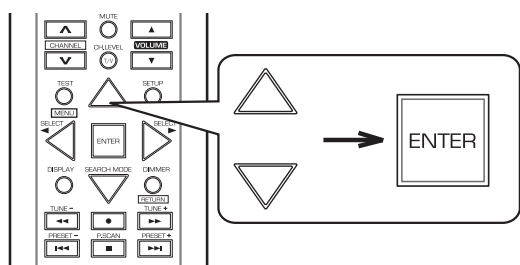

- Then "RF" (or "IR") is displayed.
- If "RF" (or "IR") goes off, start again from the above step 1.

3. While "RF" (or "IR") is displayed, press the CURSOR UP(▲)/DOWN(▼) buttons to select the desired transmission signal, then press the ENTER button.

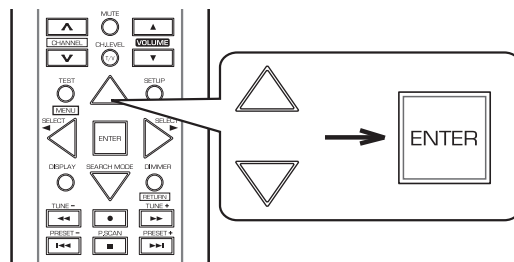

- Each time the CURSOR UP(▲)/DOWN(▼) buttons are pressed, the mode changes as follows :
"RF" : This remote control emits the RF(Radio Frequency) beams which are stronger than the infrared beams.



- "IR" : This remote control emits the infrared beams which the conventional remote control uses.

- Then "OK" is displayed.

■ When "RF" is set to.

4. To pair up this remote control and the receiver, press the TUNING UP(+) button and the ENTER/MEMORY button simultaneously on the receiver.

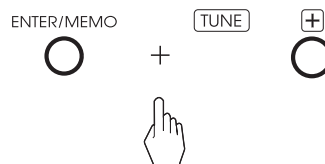

- "RF REMOCON PAIRING MODE" is displayed for several seconds on the display of the receiver.
- If "RF REMOCON PAIRING MODE" goes off, press these buttons again.

5. While "RF REMOCON PAIRING MODE" is displayed, press the ENTER button, aiming at the receiver.

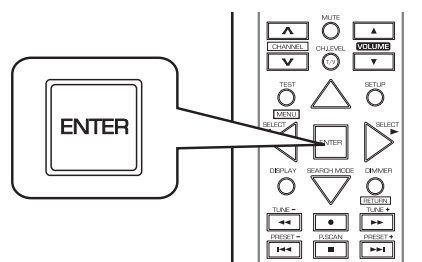

- Then "PAIRING SUCCESS" is displayed.

ROOM 2 Remote Controls

This remote control unit is an additional remote control unit for the ROOM 2 source playback only.

- You can use the ROOM 2 functions with this remote control unit more conveniently in another room than with the universal remote control unit.
- For details on ROOM 2 operation, refer to "Listening to ROOM 2 source" on page 54.

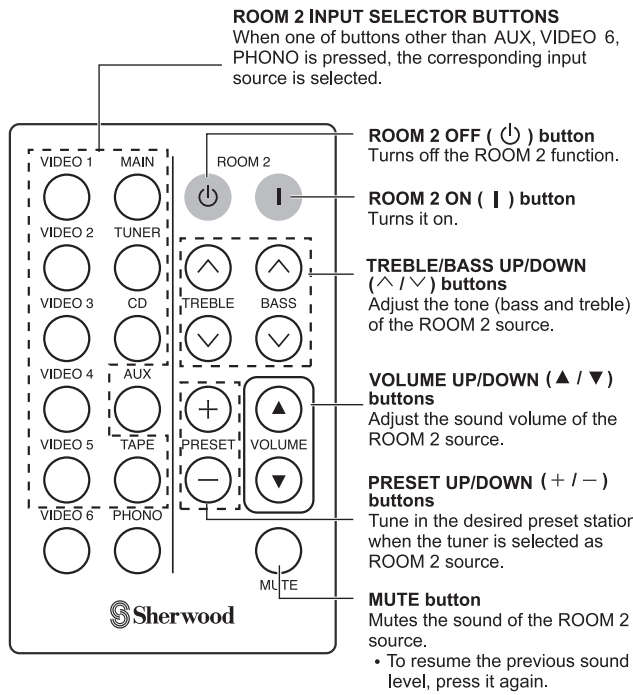

REMOTE CONTROL OPERATION RANGE

- Aim the ROOM 2 remote control at the IR receiver installed in other room. (For details, refer to "CONNECTING MULTI-ROOM SYSTEM KIT" on page 15.)

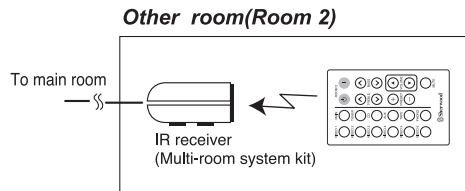

- When you operate the ROOM 2 function in the main room, aim the ROOM 2 remote control at the remote sensor of the receiver.

LOADING BATTERY

1. Remove the cover.

2. Load the battery(CR2025) matching the polarity.

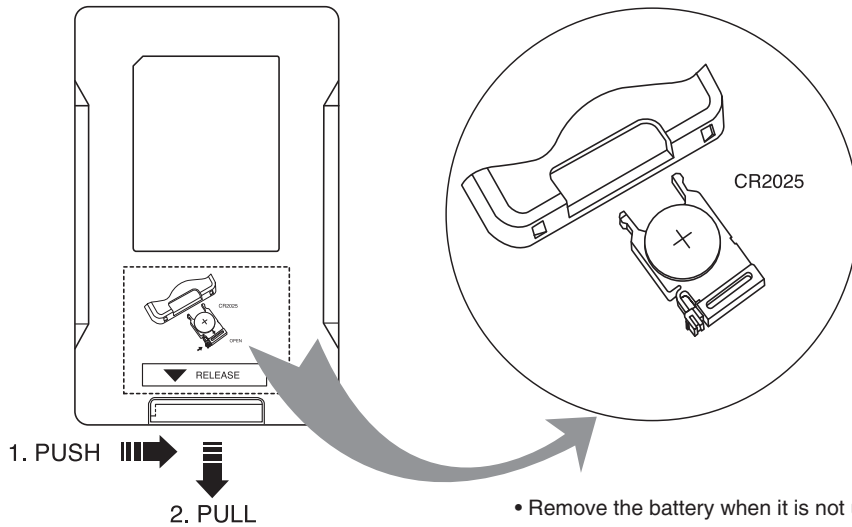

Operations

■ Notes:

- Before operating this receiver with the supplied remote control, refer to "Universal Remote Controls" on page 19 for details about operation.
- Before operating this receiver, first set this unit as desired for optimum performance, doing the OSD menu setting procedures. (For details, refer to "OSD Menu Settings" on page 56.)

LISTENING TO A PROGRAM SOURCE

Before operation

- Enter the standby mode.
- The POWER ON/STANDBY button lights up amber. This means that the receiver is not disconnected from the AC mains and a small amount of current is retained to support the operation readiness.
- To switch the power off, push the POWER switch again.
Then the power is cut off and the POWER ON/STANDBY button goes off.



1. In the standby mode, turn the power on.

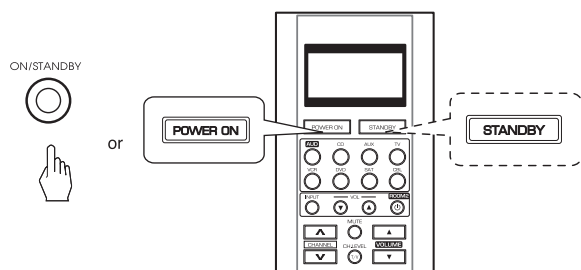

- Each time the POWER ON/STANDBY button on the front panel is pressed, the receiver is turned on to enter the operating mode (the POWER ON/STANDBY button lights up blue) or off to enter the standby mode (the POWER ON/STANDBY button lights up amber).
- On the remote control, press the POWER ON button to enter the operating mode or press the STANDBY button to enter the standby mode.

2. Switch the speakers on.

- Then the SPEAKER indicator () lights up and the sound can be heard from the speakers connected to the speaker terminals.
- When using the headphones for private listening, press the SPEAKER button again to switch the speakers off.



3. Select the desired input source.

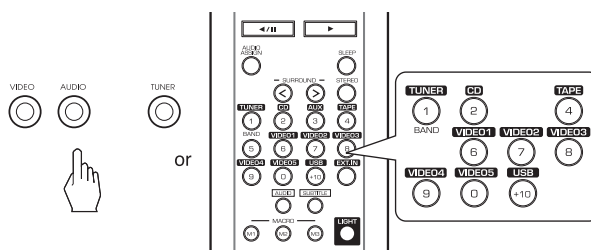

- Each time the "AUDIO" button on the front panel is pressed, the input source changes as follows:
→ CD → TAPE → USB
- Each time the "VIDEO" button on the front panel is pressed, the input source changes as follows:
→ VIDEO 1 → VIDEO 2 → --- → VIDEO 5
- Each time the "TUNER" button is pressed, the band changes as follows:
→ FM STEREO → FM MONO → AM → XM

■ When selecting the EXTERNAL IN as desired,

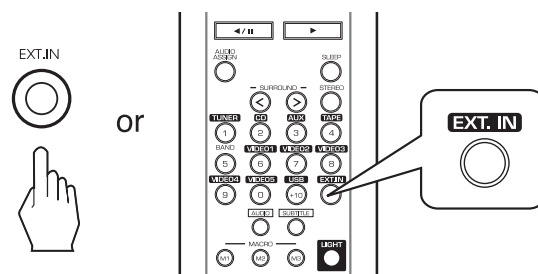

- Depending on the power amplifier setting for the surround back channels and the surround back speaker setting, "EXT. IN" is displayed and 8(/7/6) separate analog signals from the component connected to this input pass through the volume circuits only and can be heard from your speakers.
- Select the desired input source to cancel the external in function.
- These analog signals can be heard only, not recorded.

4. Operate the selected component for playback.

- When playing back the program sources with surround sound, refer to "ENJOYING SURROUND SOUND" on page 39.

5. Adjust the (overall) volume.

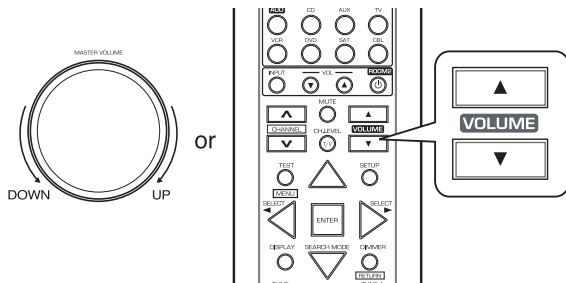

Muting the sound

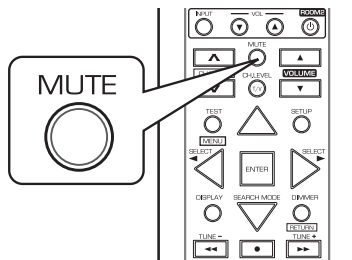

- "MUTE" flickers.
- To resume the previous sound level, press it again.

Listening with headphones

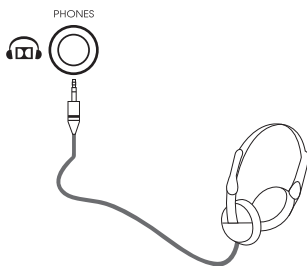

- Ensure that the SPEAKER button is set to off.
- Depending on the signal format which is being input, you can listen in Dolby Headphone mode, stereo mode, etc. (For details, refer to "Listening in Dolby Headphone mode" on page 40).
- When the EXTERNAL IN is selected as an input source, only front left and front right channel signals can be reproduced through the headphones.

■ Note:

- Be careful not to set the volume too high when using headphones.

Achieving a more detailed sound reproduction



- The RE-MASTERING indicator lights up, the remastering processes the input signal digitally and converts its digital sampling frequency to twice the current frequency (88.2/96 kHz or 176.4/192 kHz) for a more detailed sound reproduction.
- Press this button again to cancel the remastering function.

■ Note:

- The remastering function has an effect on the digital input signal from only the 88.2/96 kHz PCM (2 channel) source or lower.
- When the remastering function is activated, the stereo mode is automatically selected.

Achieving higher purity of sound quality



- The PURE AUDIO indicator lights up, the fluorescent display goes off and all the video-related circuits are turned off, meaning no video signal transfer.
- When the pure audio is activated, the optimum surround mode (or stereo mode, etc.) will be automatically selected depending on the signal format being input.
- Press this button again to cancel the pure audio function.

QUICK SETUP

- You can also make settings for input sources directly by using some buttons on the front panel without performing OSD menu setting procedures.

Setting the MONITOR OUTPUT

- You should select the MONITOR OUT which is connected to your TV.
- Depending on the VIDEO MODE setting, this unit can convert video signals and output them from the MONITOR OUT to which the MONITOR OUTPUT is set. (For details, refer to "Video conversion" on page 7.)

■ Note:

- If no picture or no OSD menu will be displayed on your TV, be sure to set the MONITOR OUTPUT and the VIDEO MODE correctly.

1. Press the MONITOR OUTPUT button.



- "MONITOR ~" is displayed for several seconds.
- When "MONITOR ~" disappears, press the MONITOR OUTPUT button again.

2. Select the desired monitor output mode while displaying "MONITOR ~".

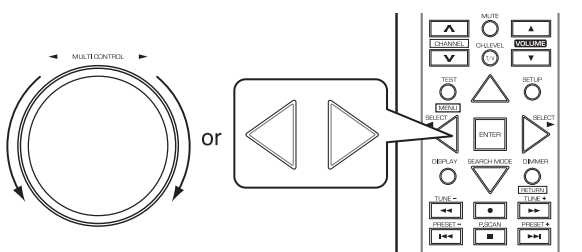

- Each time the MULTI CONTROL knob is rotated or the CURSOR LEFT(◀)/RIGHT(▶) buttons are pressed, the corresponding monitor output mode is selected as follows :

- HDMI : The video signals are output from the HDMI MONITOR OUT only.
- ↕
- COMPONENT : The video signals are output from the COMPONENT MONITOR OUTs only.
- ↕
- SCVID(E0) : The video signals are output from the (composite) VIDEO, the S-VIDEO and the COMPONENT MONITOR OUTs.

Assigning the HDMI INs

- You should assign the connected HDMI INs to the desired of VIDEO 1 ~ VIDEO 5. (For details, refer to "CONNECTING VIDEO COMPONENTS" on pages 6~8.)

1. Press the HDMI ASSIGN button.



- "HDMI ~" is displayed for several seconds.
- When "HDMI ~" disappears, press the HDMI ASSIGN button again.

2. Select the desired of HDMI 1 ~ HDMI 4, while displaying "HDMI ~".

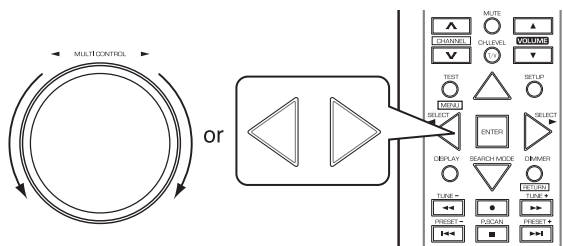

- Each time the MULTI CONTROL knob is rotated or the CURSOR LEFT(◀)/RIGHT(▶) buttons are pressed, the corresponding HDMI IN is selected as follows :

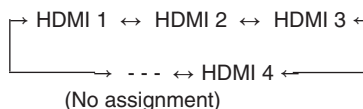

■ Note:

- In such a case that a HDMI IN is assigned two input sources or more, when these input sources are selected, the uncompressed digital video signals (and digital audio signals when the HDMI Audio Output is set to On) input into the same HDMI IN can be output from the HDMI MONITOR OUT of this receiver.



Assigning the COMPONENT VIDEO INs

- You should assign the connected COMPONENT VIDEO INs to the desired of VIDEO 1 ~ VIDEO 5. (For details, refer to "CONNECTING VIDEO COMPONENTS" on pages 6~8.)

1. Press the VIDEO ASSIGN button.

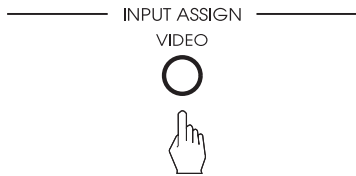

- "VIDEO ~" is displayed for several seconds.
- When "VIDEO ~" disappears, press the VIDEO ASSIGN button again.

2. Select the desired of COMP 1 ~ COMP 3 while displaying "VIDEO ~".

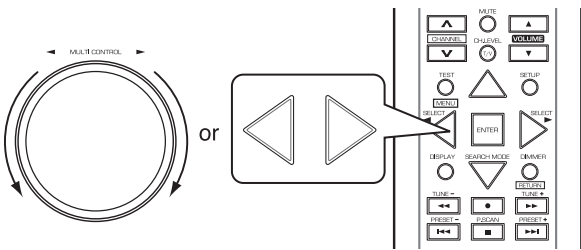

- Each time the MULTI CONTROL knob is rotated or the CURSOR LEFT(◀)/RIGHT(▶) buttons are pressed, the corresponding COMPONENT VIDEO IN is selected as follows :

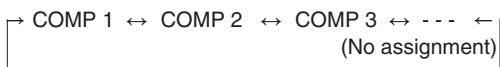

■ Note:

- In such a case that a COMPONENT VIDEO IN is assigned to two input sources or more, when these input sources are selected, the component video signals can be viewed from the same COMPONENT VIDEO IN.

Setting the AUDIO MODE

- You should select the audio input signal to be played.

■ Notes:

- Be sure to set the AUDIO MODE to the audio input which is connected and assigned to the selected input source.
- When the HDMI Audio Output is set to On, no sound will be heard from the speakers connected to this receiver (except ROOM 2 speakers). (For details, refer to "When selecting the HDMI Audio Output" on page 60.)
- When the HDMI Audio Output is set to On to play the audio signal on your TV, depending on the AUDIO MODE setting, this unit can convert the corresponding audio signal to the PCM 2 channel signals and output them from the HDMI MONITOR OUT. (For details, refer to "Audio conversion" on page 8.)
- When the AUDIO MODE is set to HDMI, you should connect the HDMI INs and assign them correctly. If not, the "HDMI" indicator flickers on the unit's display and no sound will be heard.
- When the AUDIO MODE is set to DIGITAL, you should connect the DIGITAL INs and assign them correctly. If not, the "DIG." indicator flickers on the unit's display and no sound will be heard.

1. Press the AUDIO MODE button.

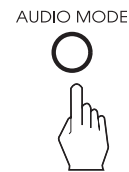

- "A.MODE ~" is displayed for several seconds.
- When "A.MODE ~" disappears, press the AUDIO MODE button again.

2. Select the desired audio input mode while displaying "A.MODE ~".

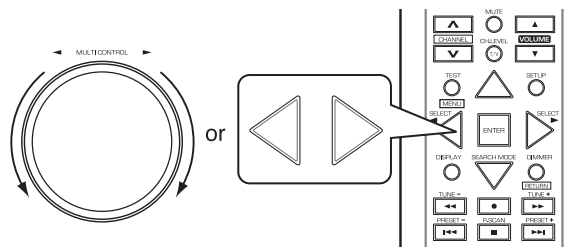

Continued

- Each time the MULTI CONTROL knob is rotated or the CURSOR LEFT(◀)/RIGHT(▶) buttons are pressed, the corresponding audio input mode is selected as follows :
 - AUTO : When there are multiple audio input signals, the audio input signals are detected and the audio input signal to be played is selected automatically in the priority of them :
HDMI audio>DIGITAL audio>ANALOG audio
 - HDMI : The signal that is input into the HDMI IN is always played.
 - DGTL : The signal that is input into the OPTICAL or (DIGITAL) the COAXIAL DIGITAL IN is always played.
 - ANLG : The signal that is input into the analog (ANALOG) AUDIO INs is always played.

Assigning the DIGITAL INs

- You should assign the connected DIGITAL INs to the desired of CD and VIDEO 1 ~ VIDEO 5.
- If the AUDIO MODE is set to the mode other than "DIGITAL", you cannot hear the sound from the selected digital input. (For details, refer to "Setting the AUDIO MODE" on this page.)

1. Press the AUDIO ASSIGN button.

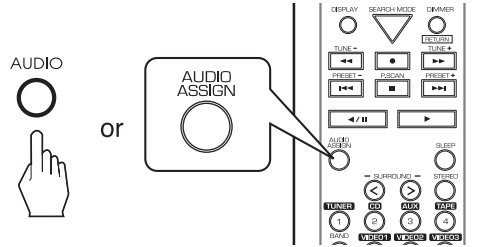

- "AUDIO ~ " is displayed for several seconds.
- When "AUDIO ~ " disappears, press the AUDIO ASSIGN button again.

2. Select the desired of the digital inputs connected while displaying "AUDIO ~ ".

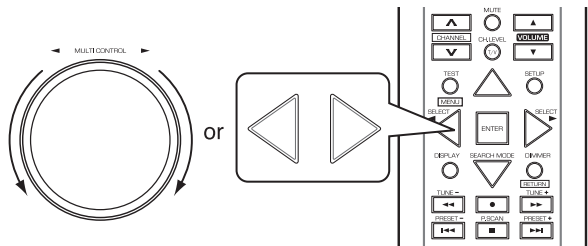

- Each time the MULTI CONTROL knob is rotated or the CURSOR LEFT(◀)/RIGHT(▶) buttons are pressed, the corresponding input is selected as follows :

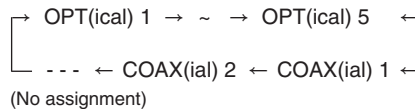

Notes:

- When the selected digital input is not connected, the "DIG." indicator flickers and no sound will be heard.
- In such a case that a DIGITAL IN is assigned to two input sources or more, when these input sources are selected, the digital audio signals can be heard from the same DIGITAL IN.

SURROUND SOUND

- This receiver incorporates a sophisticated Digital Signal Processor that allows you to create optimum sound quality and sound atmosphere in your personal Home Theater.

Surround modes

■ DTS Digital Surround

DTS Digital Surround(also called simply DTS) supports up to 5.1 discrete channels and uses less compression for high fidelity reproduction. Use it with DVDs and CDs bearing the DTS logo.

■ DTS-ES™ Discrete 6.1

This is a 6.1 channel discrete digital audio format adding a surround back channel to the DTS digital surround sound. The seven totally separate audio channels provide better spatial imaging and 360 degrees sound localization, perfect for sounds that pan across the surround channels. Use it with DVDs bearing the DTS-ES logo, especially those with a DTS-ES Discrete sound track.

■ DTS - ES™ Matrix 6.1

This is a 6.1 channel discrete digital audio format inserting a surround back channel to the DTS digital surround sound through matrix encoding. Use it with DVDs bearing the DTS-ES logo.

■ DTS Neo : 6™ surround

DTS Neo : 6 is a matrix decoding technology for achieving 7.1 channel surround playback with 2 channel sources. It includes "DTS Neo : 6 Cinema" suited for playing movies and "DTS Neo : 6 Music" suited for playing music.

■ DTS 96/24

This is high resolution DTS with a 96 kHz sampling rate and 24 bit resolution, providing superior fidelity. Use it with DVDs bearing the DTS 96/24 logo.

■ DTS-HD High Resolution Audio

Developed for use with HDTV, including the new video disc formats Blu-ray and HD DVD, this is the latest multi-channel audio format from DTS. It supports up to 7.1 channels with 96 kHz/24 bit sampling rate and signal resolution.

■ DTS-HD Master Audio

Designed to take full advantage of the additional storage space offered by the new Blu-ray and HD DVD disc formats, this new DTS format offers up to 7.1 discrete channels of uncompressed digital audio with 96 kHz/24 bit sampling rate and signal resolution.

This receiver supports 7.1 channel sources up to 96 kHz and 5.1 channel sources up to 192 kHz.

Manufactured under license under U.S. Patent #'s: 5,451,942; 5,956,674; 5,974,380; 5,978,762; 6,226,616; 6,487,535; 7,212,872; 7,333,929; 7,392,195; 7,272,567 & other U.S. and worldwide patents issued & pending.

DTS is a registered trademark and the DTS logos, Symbol, DTS-HD and DTS-HD Master Audio are trademarks of DTS, Inc.

© 1996-2008 DTS, Inc. All Rights Reserved.

■ Dolby Digital

Dolby Digital is the multi-channel digital signal format developed by Dolby Laboratories. Discs bearing the Dolby Digital logo includes the recording of up to 5.1 channels of digital signals. This will put you right in the middle of the action, just like being in a movie theater or concert hall.

■ Dolby Digital EX

This mode expands 5.1-channel sources for 6.1/7.1 channel playback. It's especially suited to Dolby Digital EX soundtracks that include a matrix-encoded surround back channel. The additional channel adds an extra dimension and provides an enveloping surround sound experience, perfect for rotating and fly-by sound effects.

■ Dolby Digital Plus

Developed for use with HDTV, including the new video disc formats Blu-ray and HD DVD, this is the latest multichannel audio format from Dolby. It supports up to 7.1 channels with 48 kHz/24-bit sampling rate and signal resolution.

■ Dolby TrueHD

Designed to take full advantage of the additional storage space offered by the new Blu-ray and HD DVD disc formats, this new Dolby format offers up to 7.1 discrete channels of lossless audio performance with 96 kHz/24 bit sampling rate and signal resolution.

■ Dolby Pro Logic Ix surround

This mode expands any 2-channel source for 7.1-channel playback. It provides a very natural and seamless surround sound experience that fully envelopes the listener. As well as music and movies, video games can also benefit from the dramatic spatial effects and vivid imaging. It includes "Dolby Pro Logic Ix Movie" suited for playing movies, "Dolby Pro Logic Ix Music" suited for playing music and "Dolby Pro Logic Ix Game" suited for playing games.

■ Dolby Pro Logic II surround

If you are not using any surround back speakers, Dolby Pro Logic II surround will be used instead of Dolby Pro Logic Ix surround. It includes Dolby Pro Logic II Movie, Dolby Pro Logic II Music and Dolby Pro Logic II Game like Dolby Pro Logic Ix surround.

■ Dolby Virtual Speaker

This mode creates a virtual surround sound field using as few as two front speakers, allowing you to experience listening from 5.1 channel speakers.

This mode is effective not only for 5.1 channel sources but also for 2 channel sources.

Dolby Virtual Speaker includes two listening mode as follows:

- **Dolby Virtual Speaker Reference**

The width of the front sound image is defined by the actual distance between front speakers.

- **Dolby Virtual Speaker Wide**

The width of the front sound image seems to extend beyond the front speakers.

■ Dolby Headphone

The Dolby Headphone function simulates 5.1 channel surround sound, which allows you to enjoy 5.1 channel surround sound through 2 channel headphones, just like listening from 5.1 channel speakers.

This mode is effective not only for 5.1 channel sources but also for 2 channel sources.

Dolby and the double-D symbol are registered trademarks of Dolby Laboratories.

■ Neural Surround™

Neural Surround represents the latest advancement in surround technology developed for music and is adopted by XM Satellite Radio for digital radio broadcast of surround recordings and live events in surround sound.

Neural Surround employs psychoacoustic frequency-domain processing, which allows delivery of a more detailed sound stage, with superior channel separation and localization of audio elements. System playback is scalable from 5.1 to 7.1 multichannel surround playback.

This product contains technology manufactured under license from Neural Audio Corporation. Sherwood Corporation hereby grants the user a non-exclusive, nontransferable, limited license right to use this product

- When using the EXTERNAL INs to play back the sound from the additional multi-channel decoder for surround sound, you can enjoy the corresponding surround sound, too. (For details, refer to the operating instructions of the component to be connected.)

For your reference, the sound from each channel can be reproduced according to the surround modes as follows:

Modes	Channels	FRONT L/R	CENTER	SURROUND L/R	SURROUND BACK L/R	SUBWOOFER
DTS-HD HIGH RESOLUTION AUDIO/MASTER AUDIO		○	○	○	○/—	○
DTS, DTS 96/24		○	○	○	—	○
DTS ES DISCRETE/MATRIX		○	○	○	○	○
DTS NEO: 6 CINEMA/MUSIC		○	○	○	○	—(*)
DOLBY DIGITAL PLUS / DOLBY TRUEHD		○	○	○	○/—	○
DOLBY DIGITAL		○	○	○	—	○
DOLBY DIGITAL EX		○	○	○	○	○
DOLBY PRO LOGIC Iix MOVIE/MUSIC/GAME		○	○	○	○	○
DOLBY PRO LOGIC II MOVIE/MUSIC/GAME		○	○	○	—	○
DOLBY VIRTUAL SPEAKER		○	○	○	—	—(*)
MULTI PCM, NEURAL		○	○	○	○/—	○
Other Surrounds		○	○	○	○	—(*)
STEREO		○	—	—	—	—(*)
EXTERNAL IN		○	○	○	○	○

(*): Depending on the subwoofer setting, the sound from the subwoofer channel may be reproduced.

- Depending on the speaker settings and the number of the encoded channels, etc., the sound from the corresponding channels cannot be reproduced.(For details, refer to "SETTING THE SPEAKER / LISTENING SETUP" on page 61.)

under the US and foreign patents pending and other related technology owned by Neural Audio Corporation.

Neural Surround is a trademark owned by Neural Audio Corporation, THX is a trademark of THX Ltd., which may be registered in some jurisdictions. All rights reserved.

- The following modes apply conventional 2-channel signals such as digital PCM or analog stereo signals to high performance Digital Signal Processor to recreate sound fields artificially. Select one of the 7 provided surround modes according to the program source you want to play.

■ Theater

This mode provides the effect of being in a movie theater when watching a play.

■ Hall

This mode provides the ambience of a concert hall for classical music sources such as orchestral, chamber music or an instrumental solo.

■ Stadium

This mode provides the expansive sound field to achieve the true stadium effect when watching baseball or soccer games.

■ Room

This mode provides the sound field of a house with a low ceiling and hard walls for jazz music.

■ Panorama

This mode provides a dynamic and broad sound space to heighten the overall impact of the sound track.

■ Classic

This mode provides the acoustic effects of a large concert hall for classical music.

■ Multi CH Stereo

This mode is designed for playing background music. The front, surround and surround back channels create a stereo image that encompasses the entire area.



ENJOYING SURROUND SOUND

■ Notes:

- Before surround playback, first perform the speaker setup procedure, etc. on the OSD menu for optimum performance. (For details, refer to "SETTING THE SPEAKER / LISTENING SETUP" on page 61.)
- When playing digital signals from the Dolby Digital, Dolby TrueHD or DTS program source or selecting the surround mode such as Dolby Pro Logic II /Dolby Pro Logic IIx Music, Dolby Headphone, Dolby Virtual Speaker modes, you can adjust their parameters for optimum surround effect. (For details, refer to "SETTING THE SOUND PARAMETER" on page 75.)
- When the EXTERNAL IN is selected as an input source, the surround modes cannot be selected.

Depending on how to select a surround mode, select the auto surround mode or the manual surround mode.

SURROUND



- Each time this button is pressed, the mode changes as follows :
Auto surround mode : The optimum surround mode will be automatically selected depending on the signal format being input. ("AUTO" lights up.)

Manual surround mode : You can select the desired of different surround modes selectable for the signal being input with using the MULTI CONTROL knob or the SURROUND MODE UP/DOWN (>/<) buttons.

■ Notes :

- Even when the auto surround mode is selected and the same type of digital signal format is being input, the optimum surround mode may vary depending on whether the speaker is set to "No" or not.
- When the auto surround mode is selected, the surround modes other than the optimum surround mode cannot be selected.

- When selecting the manual surround mode with pressing the SURROUND MODE button on the front panel.

Select the desired surround mode.

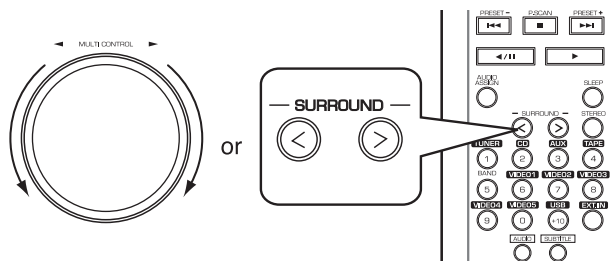

- Each time the MULTI CONTROL knob is rotated or the SURROUND MODE UP / DOWN (>/<) buttons are pressed, the surround mode changes depending on the input signal format as follows :

Signal format being input	Selectable surround mode
Dolby Digital Plus sources	DOLBY DIGITAL PLUS
Dolby TrueHD sources	Dolby TrueHD
Dolby Digital EX 6.1 channel sources, Dolby Digital 5.1 channel sources	<DOLBY DIGITAL EX, DOLBY D + PLIIx MUSIC>, (DOLBY D + PLIIx MOVIE), DOLBY DIGITAL, DOLBY VS REF, DOLBY VS WIDE
Dolby Digital 2 channel sources	<DOLBY PLIIx MOVIE, DOLBY PLIIx MUSIC, DOLBY PLIIx GAME>, [DOLBY PLII MOVIE, DOLBY PLII MUSIC, DOLBY PLII GAME], DOLBY VS REF, DOLBY VS WIDE
DTS-HD High Resolution Audio sources	DTS-HD HRA
DTS-HD Master Audio sources	DTS-HD MSTR
DTS ES Discrete/Matrix 6.1 channel sources	<corresponding DTS ES mode, DTS + PLIIx MUSIC>, (DTS + PLIIx MOVIE), DTS, DOLBY VS REF, DOLBY VS WIDE
DTS sources, DTS 96/24 sources	corresponding DTS mode, DOLBY VS REF, DOLBY VS WIDE, <DTS + NEO:6, DTS + PLIIx MUSIC>, (DTS + PLIIx MOVIE)
PCM (multi-channel) sources*	MULTI PCM, <DOLBY PLIIx MOVIE, DOLBY PLIIx MUSIC>, DOLBY VS REF, DOLBY VS WIDE
PCM (2 channel) sources**, Analog stereo sources	<DOLBY PLIIx MOVIE, DOLBY PLIIx MUSIC, DOLBY PLIIx GAME>, [DOLBY PLII MOVIE, DOLBY PLII MUSIC, DOLBY PLII GAME], DOLBY VS REF, DOLBY VS WIDE, NEO:6 CINEMA, NEO:6
Music files from USB***	MUSIC, NEURAL, THEATER, HALL, STADIUM, ROOM, PANORAMA, CLASSIC, MULTI-CH STEREO

- Depending on surround back speaker setting, some surround modes can be selected or not as follows:

< > : Possible only when surround back speaker is not set to "No".

[] : Possible only when surround back speaker is set to "No".

() : Possible only when surround back speaker is set to "2 ch".

- When the Trinnov Position is not set to "None", the Dolby Virtual Speaker modes cannot be selected. (For details, refer to "When selecting the Trinnov Position" on page 72.)

* : Depending on the signal format being input, the Dolby Pro Logic IIx modes and the Dolby Virtual Speaker modes may not be selected.

** : While playing 192kHz PCM(2channel) sources, the Neural Surround mode cannot be selected.

*** : While playing music files from USB, the DTS Neo : 6 and Neural Surround modes cannot be selected.



Continued

■ To cancel the surround mode for stereo operation

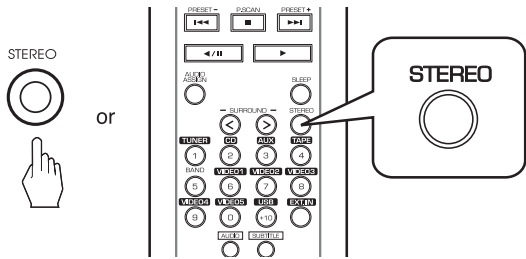

- Depending on the signal format which is being input, either the stereo mode or the 2CH downmix mode is selected.
- To cancel either the stereo mode or the 2CH downmix mode, select the surround mode with using the MULTI CONTROL knob on the front panel or the SURROUND MODE UP/DOWN (>/<) buttons on the remote control.

■ 2CH downmix mode

- This mode allows the multi-channel signals encoded in DTS or Dolby Digital format, etc. to be mixed down into 2 front channels and to be reproduced through only two front speakers or through headphones.
- When the SPEAKER button is set to off to listen with headphones, if the STEREO button is pressed while playing the multi-channel digital signals from DTS or Dolby Digital sources, etc., it will enter the 2CH downmix mode automatically.
- To cancel the 2CH downmix mode, select the Dolby Headphone mode with using the MULTI CONTROL knob on the front panel or the SURROUND MODE UP/DOWN (>/<) buttons on the remote control.

Listening in Dolby Headphone mode

- The Dolby Headphone function simulates 5.1 channel surround sound, which allows you to enjoy 5.1 channel surround sound through 2 channel headphones, just like listening from 5.1 channel speakers.

■ Notes :

- Only when the SPEAKER button is set to off, the Dolby Headphone mode can be selected.
- When playing the digital signals from multi channel PCM, Dolby Digital Plus, Dolby TrueHD, DTS-HD High Resolution Audio or DTS-HD Master Audio sources, the 2 CH downmix mode only can be selected.
- Switch the speakers off to listen with headphones.



- Then " [Speaker Icon] Headphone" (or " [Speaker Icon] H ~ ") is displayed and the Dolby Headphone mode is selected.
- To cancel the Dolby Headphone mode, press the SPEAKER button again.

Adjusting each channel level with test tone

- The volume level of each channel can be adjusted easily with the test tone function.

■ Notes :

- When the SPEAKER button is set to off, the test tone function does not work.
- When EXTERNAL IN or USB is selected as an input source, the test tone function does not work.
- Only when the Trinnov Position is set to "None", the test tone function will work. (For details, refer to "When selecting the Trinnov Position" on page 72.)

1. Enter the test tone mode.

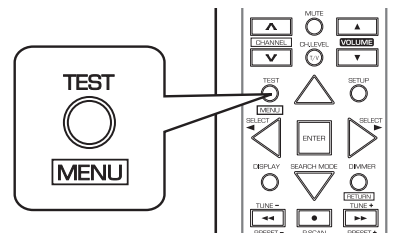

- The test tone will be heard from the speaker of each channel for 2 seconds as follows:

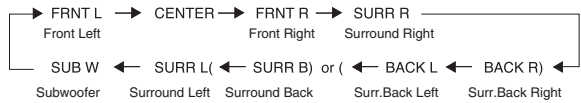

- When the speaker setting is "No", the test tone of the corresponding channel is not available.
- () : Possible depending on whether the surround back channel is set to "2 ch" or "1 ch".

2. At each channel, adjust the level as desired until the sound level of each speaker is heard to be equally loud.

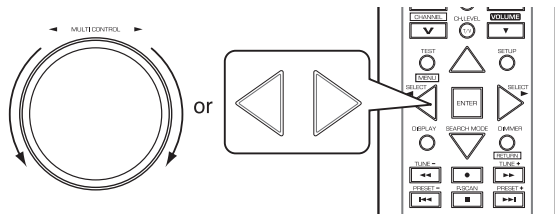

- You can select the desired channel with pressing the CONTROL UP/DOWN (▲/▼) buttons or the CURSOR UP/DOWN (▲/▼) buttons.

3. Cancel the test tone function.

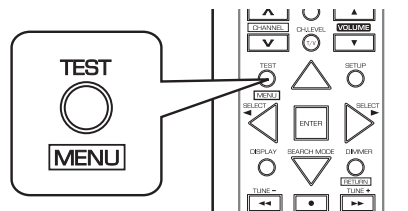

Adjusting the current channel level

- After adjusting each channel level with test tone, adjust the channel levels either according to the program sources or to suit your tastes.
- You can adjust the current channel levels as desired. These adjusted levels are just memorized into user's memory ("TRIM"), not into preset memory("REF 1", "REF 2").

Note :

- Only when the Trinnov Position is set to "None", you can adjust the channel levels, memorize and recall them. (For details, refer to "When selecting the Trinnov Position" on page 72.)

1. Press the CHANNEL LEVEL button.

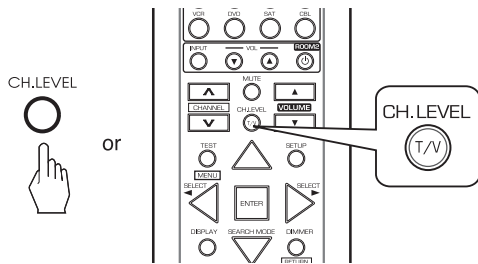

- Then the memory mode ("TRIM" or "REF 1", etc) is displayed for several seconds.
- When the memory mode or channel level disappears, press this button again.

2. Select the desired channel.

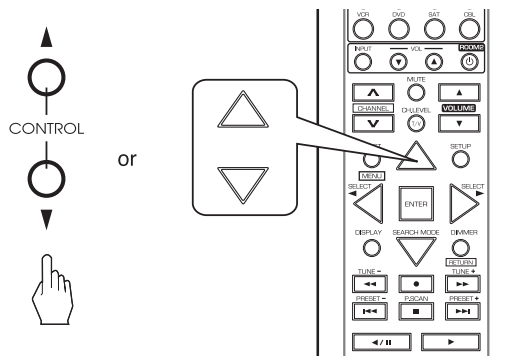

- Each time these buttons are pressed, the corresponding channel is selected as follows:



- (): Possible depending on whether the surround back channel is set to "2 ch" or "1 ch".
- < >: Possible only when the digital signals from Dolby Digital or DTS sources, etc. that include LFE signal are input.

- Depending on the speaker settings("No", etc.) and surround mode, etc., some channels cannot be selected.
- When the SPEAKER button is set to off, only the Front Left, Front Right (and LFE) channels can be selected.

3. Adjust the level of the selected channel as desired.

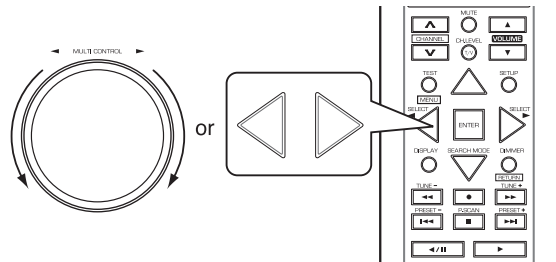

- The LFE level can be adjusted within the range of -10 ~ 0 dB and other channel levels within the range of -15 ~ +15 dB.
- In general, we recommend the LFE level to be adjusted to 0 dB.(However, the recommended LFE level for some early DTS software is -10 dB.) If the recommended levels seem too high, lower the setting as necessary.

4. Repeat the above steps 2 and 3 to adjust each channel level.

Memorizing the adjusted channel levels

- You can memorize the adjusted channel levels into preset memory ("REF 1", "REF 2") and recall the memorized whenever you want.

- After performing the steps 1~4 in "Adjusting the current channel level" procedure on page 41, press the ENTER(MEMORY) button.

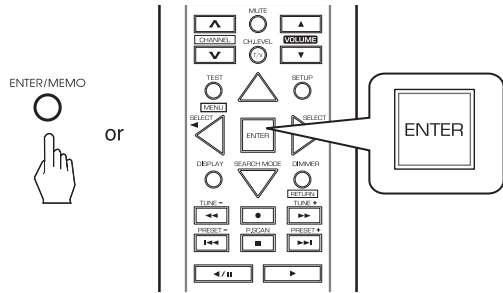

- The "1" of "REF 1" of indication flickers for several seconds.

- Select the desired one of REF 1 and REF 2.

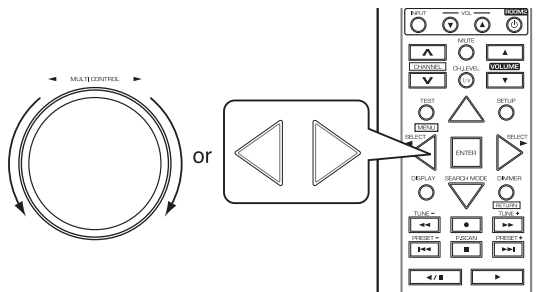

- If the preset memory disappears, perform the above step 1 again.

- Confirm your selection.

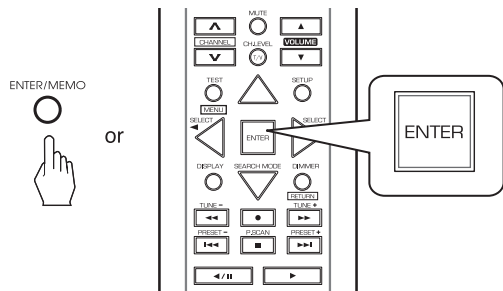

- The adjusted channel memory levels have now been memorized into the selected memory.

Recalling the memorized channel levels

- Press the CHANNEL LEVEL button.

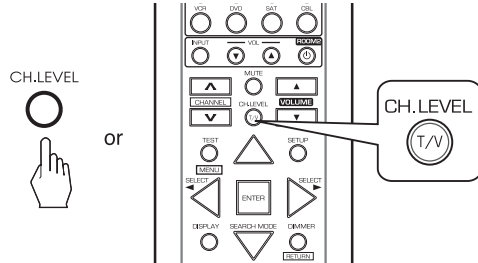

- "REF 1" (or "TRIM") is displayed for several seconds.
- If the channel level mode display disappears, press this button again.

- Select the desired one of REF 1 and REF 2.

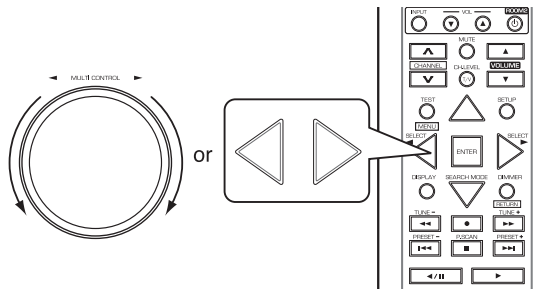

- Then the channel levels memorized into the selected memory are recalled.

LISTENING TO RADIO BROADCASTS

Auto tuning

1. Select the desired band.

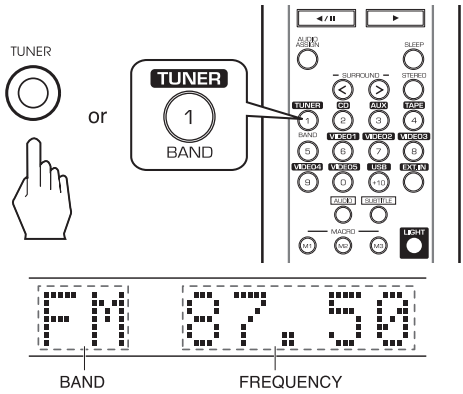

- Each time this button is pressed, the band changes as follows :
 → FM STEREO → FM MONO → AM → XM
- When FM stereo broadcasts are poor because of weak broadcast signals, select the FM mono mode ("STEREO" goes off) to reduce the noise, then FM broadcasts are reproduced in monaural sound.
- To listen to XM Satellite Radio, select XM mode. (For details, refer to "XM Satellite Radio (only for North America)" on page 45.)

2. Press the TUNING UP(+)/DOWN(-) buttons for more than 0.5 second.

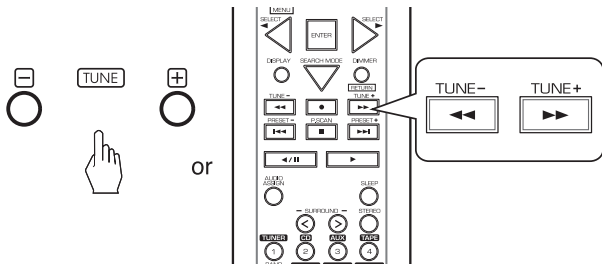

- The tuner will now search until a station of sufficient strength has been found. The display shows the tuned frequency and "TUNED".
- If the station found is not the desired one, simply repeat this operation.
- Weak stations are skipped during auto tuning.

Manual tuning

- Manual tuning is useful when you already know the frequency of the desired station.
- After selecting the desired band, press the TUNING UP(+)/DOWN(-) buttons repeatedly until the right frequency has been reached.

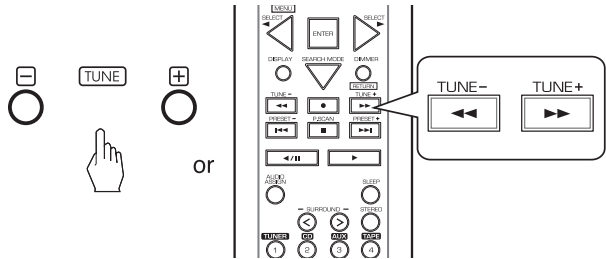

Auto presetting

- Auto presetting function automatically searches for FM stations only and stores them in the memory.
- While listening to FM or AM radio broadcasts, press and hold down the ENTER/MEMORY button for more than 2 seconds.
- Then "AUTO MEMORY" flickers and this receiver starts auto presetting.
- Up to 30 FM stations can be stored.

■ Notes:

- FM stations of weak strength cannot be memorized.
- To memorize AM stations or weak stations, perform "Manual presetting" procedure with using "Manual tuning" operation.

Manual presetting

- You can store up to 30 preferred stations in the memory.

1. Tune in the desired station with auto or manual tuning.

2. Press the ENTER/MEMORY button.



- "MEMORY" is flickering for several seconds.

3. Select the desired preset number (1~30) and press the ENTER/MEMORY button.

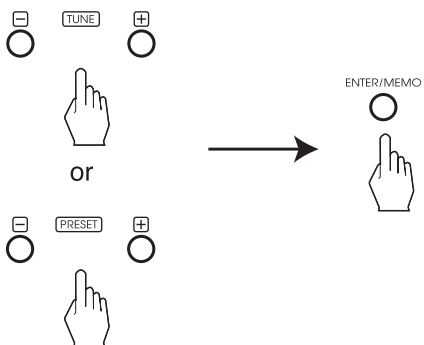

- The station has now been stored in the memory.
- A stored frequency is erased from the memory by storing another frequency in its place.
- If "MEMORY" goes off, start again from the above step 2.

4. Repeat the above steps 1 to 3 to memorize other stations.

■ MEMORY BACKUP FUNCTION

The following items, set before the receiver is turned off, are memorized.

- INPUT SELECTOR settings
- Surround mode settings
- Preset stations, etc.

Tuning to preset stations

- After selecting the tuner as an input source, select the desired preset number.

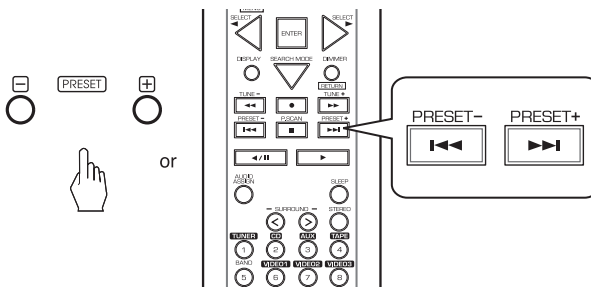

Scanning preset stations in sequence

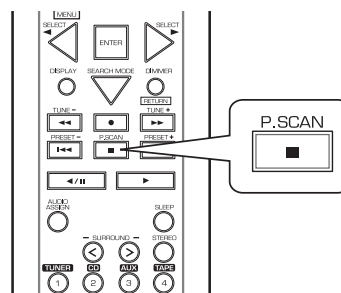

- The receiver will start scanning the stations in the preset sequence and each station is received for 5 seconds.
- At the desired station, press this button again to stop scanning.



XM Satellite Radio (only for North America)

- This receiver is the XM Ready® receiver. You can receive XM Satellite Radio® by connecting to the XM Mini-Tuner system (sold separately) and subscribing the XM service.

■ About XM Satellite Radio for U.S. & Canadian products

XM Satellite Radio offers an extraordinary variety of commercial-free music, plus the best in sports, news, talk and entertainment. XM is broadcast in superior digital audio from coast to coast. From rock to reggae, from classical to hip hop, XM has something for every music fan. XM's dedication to playing the richest selection of music is matched by its passion for live sporting events, talk radio, up-to-the-minute news, stand-up comedy, children's programming, and much more. For U.S. customers, information about XM Satellite Radio is available online at www.xmradio.com. For Canadian customers, information about XM Canada is online at www.xmradio.ca.

■ XM Ready® legal for U.S. & Canadian products

Hardware and required monthly subscription sold separately. Other fees and taxes, including a one-time activation fee may apply. Subscription fee is consumer only. All fees and programming subject to change. Channels with frequent explicit language are indicated with an XL. Channel blocking is available for XM radio receivers by calling 1-800-XMRADIO (US residents) and 1-877-GET-XMSR (Canadian residents). For a full listing of the XM commercial-free channels and advertising-supported channels, visit lineup.xmradio.com (US residents) or xmradio.ca (Canadian residents). Subscriptions subject to Customer Agreement available at xmradio.com (US residents) and xmradio.ca (Canadian residents). Only available in the 48 contiguous United States and Canada. ©2006 XM Satellite Radio Inc. All rights reserved. All other trademarks are the property of their respective owners.

■ XM Ready® subscriptions for U.S. Products & Canadian products

Once you have installed the XM Mini-Tuner Dock, inserted the XM Mini-Tuner, connected the XM Dock to your XM Ready® home audio system, and installed the antenna, you are ready to subscribe and begin receiving XM programming. There are three places to find your eight character XM Radio ID: on the XM Mini-Tuner, on the XM Mini-Tuner package, and on XM Channel 0. Record the Radio ID in the following eight squares for reference.



Note: The XM Radio ID does not use the letters "I", "O", "S" or "F". Activate your XM Satellite Radio service in the U.S. online at <http://activate.xmradio.com> or call 1-800-XM-RADIO (1-800-967-2346). You will need a major credit card. XM will send a signal from the satellites to activate the full channel lineup. Activation normally takes 10 to 15 minutes, but during peak busy periods you may need to keep your XM Ready home audio system on for up to an hour. When you can access the full channel lineup on your XM Ready home audio system you are done. For more information or to subscribe in Canada, visit XM on the Web at www.xmradio.ca or call XM's Listener Care at 1-877-GET-XMSR (1-877-438-9677).

LISTENING TO XM SATELLITE RADIO

Signing up for XM Satellite Radio

- Before using XM Satellite Radio, you must first sign up for an account. You will need a major credit card and your XM Satellite Radio ID, which you can get from this receiver as explained below.

1. Press the TUNER button repeatedly to select XM mode.

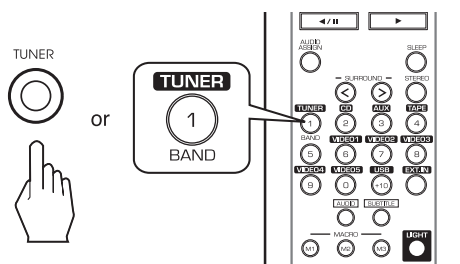

- Then XM CH ~ is displayed.

2. Press the TUNING UP(+)/DOWN(-) buttons repeatedly to select XM CH 000.

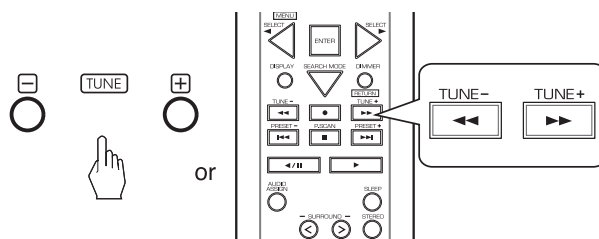

- Then your XM Satellite Radio ID is displayed.
- You can find the XM Satellite Radio ID on the XM Mini-Tuner itself and the XM Mini-Tuner package, too.

3. To sign up, access the website at

"<http://activate.xmradio.com>" or call "1-800-967-2346".



Channel search

- In the XM mode, press the TUNING UP (+)/DOWN (-) buttons repeatedly to select the desired channel.

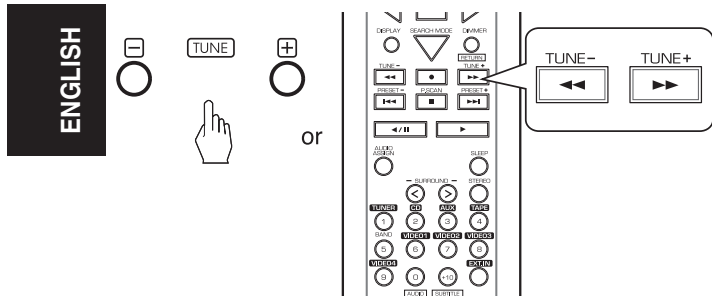

Direct search

- Direct search is useful when you already know the channel number.

1. In the XM mode, select the direct search mode.

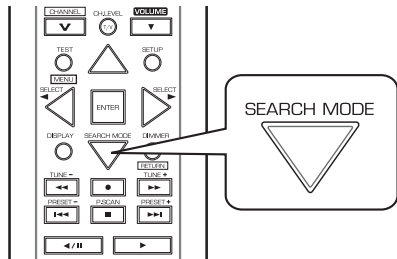

- Each time this button is pressed, the search mode changes as follows:

→ DIRECT SEARCH → CATegory search → OFF

Note:

- When using channel search or preset search, press this button to select the search off.

2. While displaying "DIRECT SEARCH", select the desired channel number with pressing the NUMERIC (0 ~ 9) buttons.

Examples: For "3" : (3)
 For "27" : (2) within 4 seconds → (7)
 For "124" : (1) within 4 seconds → (2) within 4 seconds → (4)

- When "DIRECT SEARCH" disappears, repeat again from the above step 1.

Category search

- Category search allows you to select the desired channel by the selected category.

1. In the XM mode, select the category search mode.

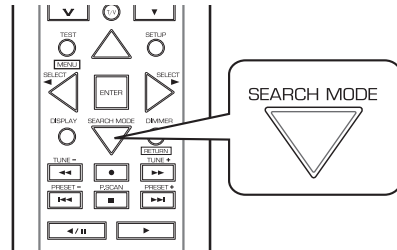

- "CAT : ~" is displayed.

2. While displaying "CAT : ~", press the SELECT ◀/▶ buttons to select the desired category, then press the ENTER button.

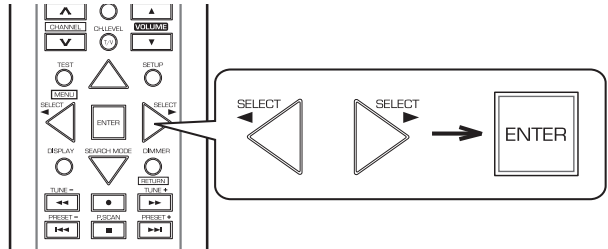

- Each time the SELECT ◀/▶ buttons are pressed, one of different categories is selected.
- When "CAT : ~" disappears, repeat again from the above step 1.

3. While displaying the selected category, select the desired channel.

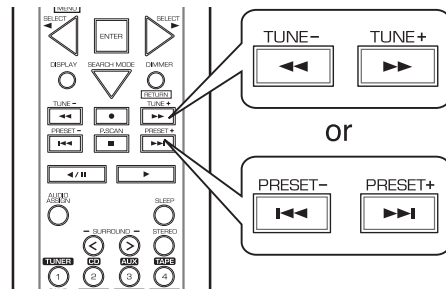

Presetting channels

- You can store up to 30 preferred channels in the memory.

1. Select the desired channel with performing channel search, direct search or category search.

2. To memorize the channels, perform the steps 2 to 4 in "Manual presetting" procedure on page 44.

Preset search

- In the XM mode, select the desired preset channel.

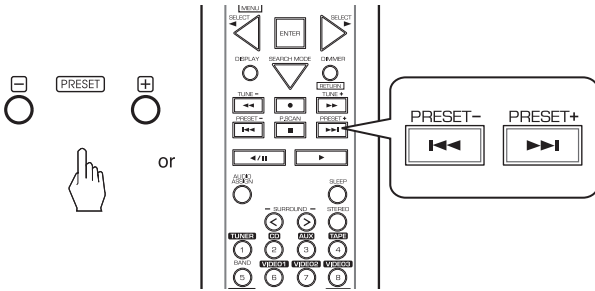

Displaying XM information

- You can display XM information such as channel name, artist name, song title and signal strength.

- In the XM mode,

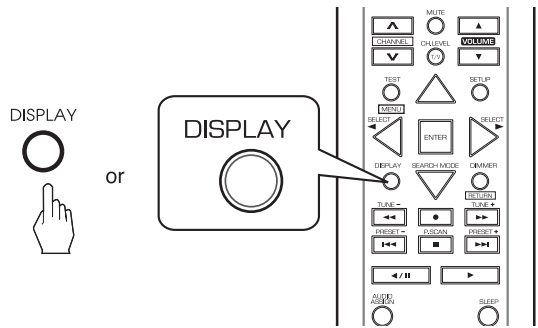

- Each time the DISPLAY button is pressed, the display mode changes as follows:

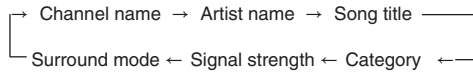

Note:

- If the information on artist name, song title or category is not available, it will not be displayed correctly.

Signal strength display mode

- If the reception is poor, you can check the signal strength of the XM radio signal and adjust the position of the XM antenna until "SIGNAL : GOOD" is displayed.

Error message and status

- If an operation takes longer than usual or an error occurs, one of the following messages may be displayed.

Message	Status
CHECK ANTENNA	The XM antenna is not connected correctly. Check the antenna.
UPDATING	The XM user encryption code is being updated. Please wait.
NO SIGNAL	The signal is too weak. Check the antenna connection and reposition it for the best reception.
LOADING	This receiver is tuning or decoding audio or text data. Please wait.
OFF AIR	The selected XM channel is not currently broadcasting. Select another channel.

ENGLISH

PLAYING MUSIC FILES

- When connecting a USB mass storage device to this unit, you can enjoy MP3 or WMA files stored on it through this receiver.

■MP3

- MP3 files must have a “.mp3” or “.MP3” file name extension.
- It is recommended that you record your material at a 44.1kHz sampling rate, using the 96~320 kbps data transfer rate.
- Fixed bit-rate files are recommended. Variable bit-rate(VBR) files are playable, but playing time may be displayed incorrectly.

■WMA

- WMA files must have a “.wma” or “.WMA” file name extension.
- It is recommended that you record your material at a bit rate of 64 kbps or higher.
- This unit cannot play files recorded with a bit rate of 80 and 256 kbps.

■Compatible USB mass storage device:

- USB flash memory(USB 2.0 or USB 1.1)
- USB flash players(USB 2.0 or USB 1.1)
- Memory cards(requires an additional card reader to work with this receiver)

■Supported formats:

- USB or memory file format FAT 16 or FAT 32.

■Notes :

- It is not possible to connect this unit to a PC for USB playback.
- We cannot guarantee compatibility with all USB mass storage devices and assumes no responsibility for any loss of data that may occur when connected to this unit.
- During USB playback, do not remove the USB device. Should this happen, it may be result in malfunction or cause damage to this unit and/or the USB device. To prevent it, after USB playback, remove the USB device in the stop mode or the standby mode.

1. Select the USB as an input source.

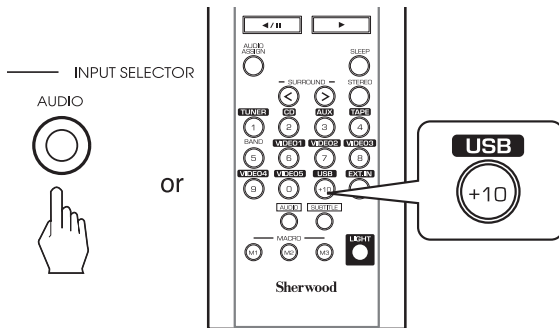

2. Connect the USB device into the USB connector on the front panel.

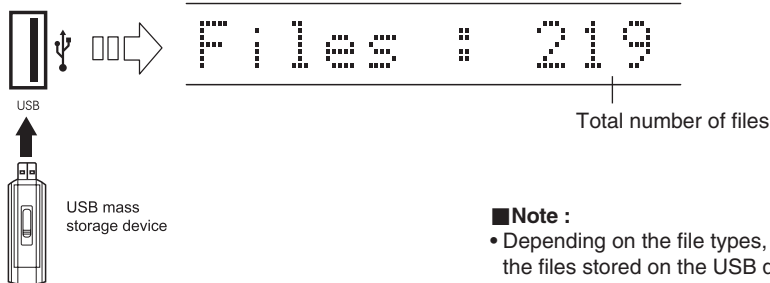

■Note :

- Depending on the file types, etc. it may take times to read the files stored on the USB device.



3. Start playback.

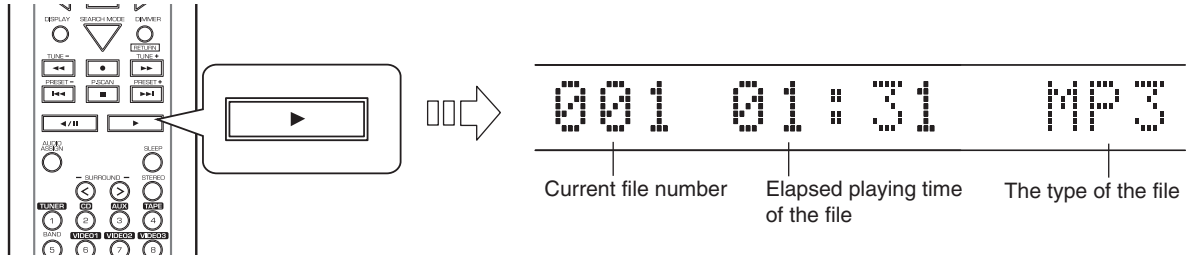

ENGLISH

4. To interrupt playback temporarily.

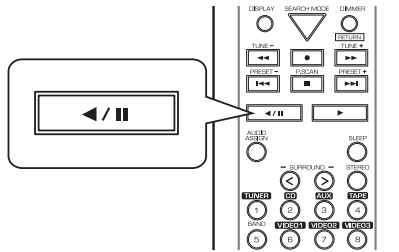

- To resume playback, press the "▶" button.

5. To stop playback.

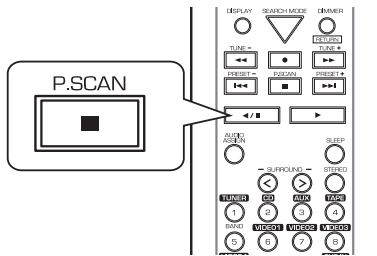

- Then playback of a file is stopped and the receiver memorizes that file where the "■" button is pressed. (Resume function).
- If the "▶" button is pressed, playback will resume from the beginning of that.
- When the "■" button is pressed while operating the resume function, it enters the STOP mode. If the "▶" button is pressed, playback will start from the first file.





ENGLISH

Skipping ahead or back during playback

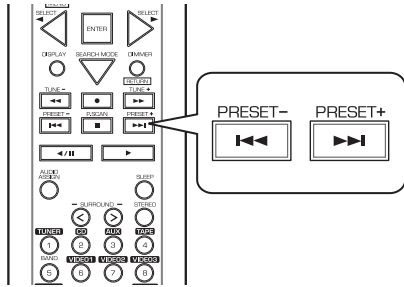

- Each time the "▶▶" button is pressed, a file is skipped.
- When the "◀◀" button is pressed once, playback returns to the beginning of that file.
- When the "◀◀" button is pressed twice, a file is skipped.

Repeat/Random playback

- You can play a file, all the files repeatedly or files in random order.
- During playback, press the SEARCH MODE button to select the desired playback mode.

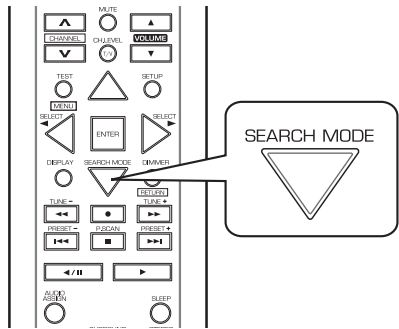

- Each time this button is pressed, the playback mode is selected as follows:

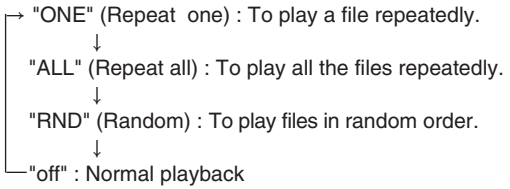

Displaying file information during playback

- You can display file information such as file name, title name, artist name and file number/elapsed playing time.

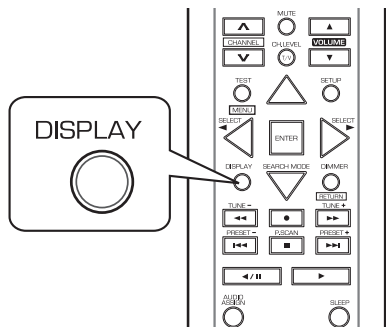

- Each time this button is pressed, the display mode changes as follows:

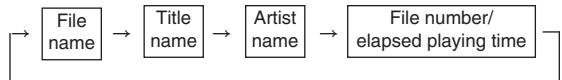

- Notes :
- If the name information is not available, it will not be displayed.
 - Characters except "A~Z", "0~9", "-" may be not displayed.



RECORDING

- The analog signals from the EXTERNAL INs as well as the digital signals from the USB IN, the HDMI IN, the OPTICAL or COAXIAL DIGITAL IN can be heard but cannot be recorded.
- When recording the analog signals from CD, VIDEO 1~5, be sure to select "Analog" for the Audio Mode. (For details, refer to "When selecting the Audio Mode" on page 71.)
- When recording the video signals from VIDEO 2~5, be sure to select "Composite" or "S-Video" for the Video Mode. (For details, refer to "When selecting the Video Mode" on page 70.)
- The volume and tone (bass, treble) settings have no effect on the recording signals.

Recording with TAPE

1. Select the desired input as a recording source except for TAPE.

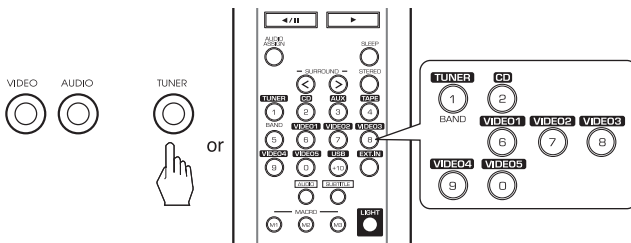

2. Start recording on the TAPE.

3. Start play on the desired input.

Dubbing from video components onto VIDEO 1

1. Select the desired of VIDEO 2 ~ 5 as a recording source except VIDEO 1.

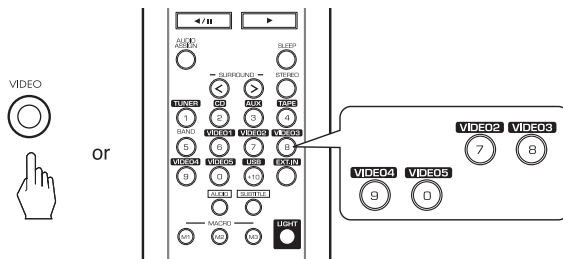

2. Start recording on the VIDEO 1.

3. Start play on the desired input.

- The audio and video signals from the desired input will be dubbed onto the VIDEO 1 and you can enjoy them on the TV set and from the speakers.

Dubbing the audio and video signals separately onto VIDEO 1

Example: When dubbing the VIDEO 2 video signal and the CD audio signal separately onto VIDEO 1.

1. Select VIDEO 2 as a video recording source.

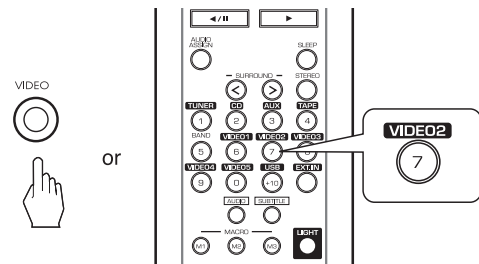

2. Select CD as an audio recording source.

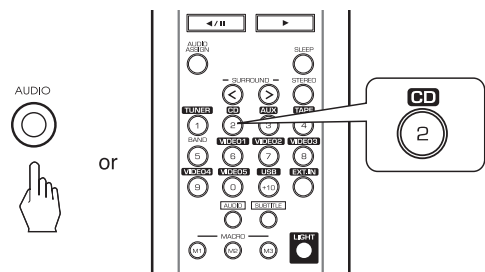

3. Start recording on the VIDEO 1.

4. Start play on the VIDEO 2 and the CD respectively.

- The audio signal from the CD and the video signal from the VIDEO 2 will be dubbed and you can enjoy them on the TV set and from the speakers.

■ Note :

- Be sure to observe the order of the above steps 1 and 2.

DIGITAL AUDIO RECORDING WITH MD RECORDER

- Only when the OPTICAL DIGITAL OUT of this receiver is connected to the OPTICAL DIGITAL IN of the MD recorder or CD recorder, you can enjoy high-quality sound of digital recording without converting the original signals. Refer to "CONNECTING VIDEO COMPONENTS", "CONNECTING AUDIO COMPONENTS" and "CONNECTING DIGITAL IN AND OUT" on pages 6 ~10 and the operating instructions of the MD recorder or CD recorder.

■ Notes:

- Depending on the digital audio signal format input into the HDMI IN connector, some digital signals cannot be output from the OPTICAL DIGITAL OUT jack.
- Digital recording is available for the digital audio program sources such as CDs, MDs, some DVDs, etc.
- There are some restrictions on recording digital signals. When making digital recordings, refer to the operating instructions of your digital recording equipment to know what restrictions are imposed.

1. Select the desired of CD, VIDEO 1~5 as a recording source.

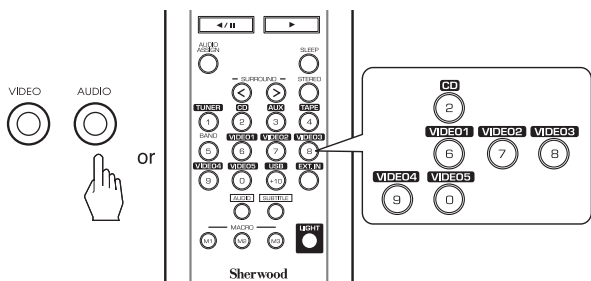

■ In case of recording the digital audio signal input into a HDMI IN connector

- Select the desired recording source to which the HDMI IN is connected and assigned and then perform the steps 3 and 4 (, but ignore the step 2).

■ Note :

- If the Audio Mode is set to the mode other than "HDMI" for the corresponding recording source on the INPUT SETUP menu, the digital audio signals will not be output and there will be no recording. (For details, refer to "When selecting the Audio Mode" on page 71.)

2. For digital recording, select the digital input as recording signal input.

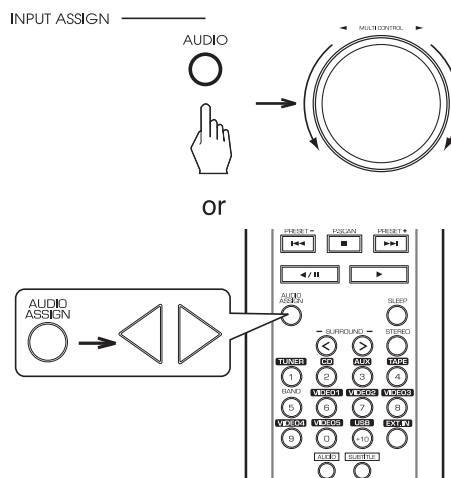

■ Note :

- If the AUDIO MODE is set to the mode other than "DIGITAL" for the corresponding recording source on the INPUT SETUP menu, the digital audio signals from the selected digital input will not be output and there will be no recording. (For details, refer to "When selecting the Audio Mode" on page 71.)

3. Start recording on the component connected to the OPTICAL DIGITAL OUT.

4. Start play on the desired input.

OTHER FUNCTIONS

Operating the sleep timer

- The sleep timer allows the system to continue to operate for a specified period of time before automatically shutting off.
- To set the receiver to automatically turn off after the specified period of time.

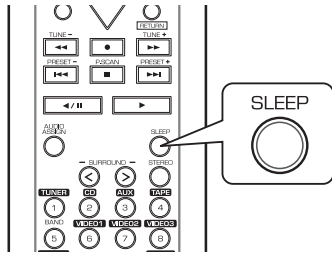

- Each time this button is pressed, the sleep time changes as follows:

→ 10 → 20 → 30 → --- → 90 → OFF
Unit : minutes

- While operating the sleep timer, " ★ " lights up.
- When the sleep time is selected, the fluorescent display is dimly lit.

Adjusting the brightness of the fluorescent display

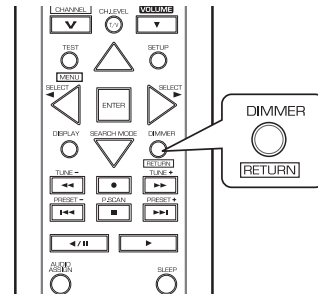

- Each time this button is pressed, the brightness of the fluorescent display changes as follows:

→ ON → dimmer → OFF

- In the display OFF mode, pressing any button will cancel the display OFF mode for several seconds to display the operation status.

MULTI ROOM OPERATION

- In addition to your main room, you can also enjoy playback in two other rooms (ROOM 2 and ROOM 3).

■ Notes:

- The analog signals from the EXTERNAL INs and the digital signals (including signals from the USB IN) cannot be output to the other rooms, meaning no playback in ROOM 2 and ROOM 3.
- The HDMI video signals and the component video signals cannot be output to the other rooms.

Listening to ROOM 2 source

- You can select different sources for main room and second room (ROOM 2) and play them at the same time.
- When you connect the multi-room system kit to the IR IN jack of this receiver, you can control this receiver with not only the universal remote control unit but also the ROOM 2 remote control unit in a second room (ROOM 2), too. (For details, refer to "CONNECTING MULTI-ROOM SYSTEM KIT" on page 15 and "ROOM 2 Remote Controls" on page 31.)

◆ When using the buttons on the remote control unit

1. Turn on the ROOM 2 function.

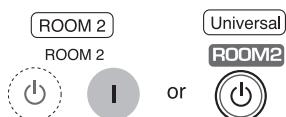

- ROOM 2 ~ is displayed for several seconds.
- On the ROOM 2 remote control, press the ROOM 2 ON (I) button to enter the ROOM 2 ON mode or press the ROOM 2 OFF (⏻) button to enter the ROOM 2 OFF mode.
- Each time the ROOM 2 button on the universal remote control is pressed, the ROOM 2 mode changes as follows :
ON : To turn on the ROOM 2 function.
□ ("MULTI") lights up.)
OFF : To turn it off. ("MULTI") or "AMP" goes off depending on the AMP ASSIGN setting.)

■ Note :

- When the ROOM 2 mode is set to OFF, you cannot adjust the ROOM 2 volume and tone (bass and treble).

2. Select the desired input as a ROOM 2 source.

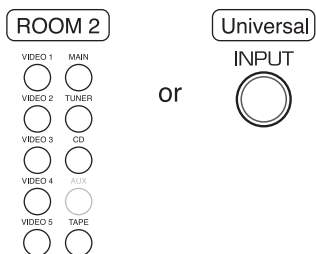

- Each time the INPUT button on the universal remote control is pressed, the ROOM 2 input can be selected among MAIN source, TUNER, CD, TAPE, VIDEO 1 ~ VIDEO 5.

■ When selecting the tuner as a ROOM 2 source

- Tune in the desired preset station using the ROOM 2 remote control.



3. Adjust the ROOM 2 volume.

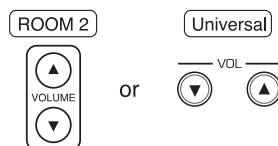

- The MUTE button on the ROOM 2 remote control can be available only when the ROOM 2 function is operating.

4. Adjust the tone (bass and treble) for ROOM 2 source.



- The tone level can be adjusted within the range of -10 ~ +10 dB.
- In general, we recommend the bass and treble to be adjusted to 0 dB (flat level).
- Extreme settings at high volume may damage your speakers.

5. Start play on the component related to the ROOM 2 source.

Continued

◆When using the buttons on the front panel

1. Press the ROOM 2 button to enter the ROOM 2 mode.



- ROOM 2 ~ is displayed for several seconds.
- When the ROOM 2 setting mode disappears, press the ROOM 2 button again.

2. Select the desired mode while displaying the ROOM 2 setting mode.



- Each time these buttons are pressed, the mode changes as follows :

- ROOM 2 ~ : To turn on or off the (ROOM 2 mode) ROOM 2 function.
- ↕
- INPUT ~ : To select the desired (ROOM 2 input) ROOM 2 source.
- ↕
- VOLUME ~ : To adjust the ROOM 2 (ROOM 2 volume) volume.
- ↕
- R2 BASS ~ : To adjust bass for ROOM 2 source.
- ↕
- R2 TRE ~ : To adjust treble.

■Note :

- When the ROOM 2 mode is set to OFF, the ROOM 2 input, the ROOM 2 volume and the tone (bass and treble) cannot be selected.

3. Set the selected mode as desired.

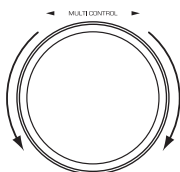

■When selecting the ROOM 2 mode.

ON : To turn on the ROOM 2 function.

↑ ("MULTI") lights up.)

OFF : To turn it off. ("MULTI" or "AMP ASSIGN" goes off depending on the AMP ASSIGN setting.)

■When selecting the ROOM 2 input.

- You can select the desired among MAIN source, TUNER, CD, TAPE, VIDEO 1 ~ VIDEO 5 as a ROOM 2 source.

■When selecting the ROOM 2 volume.

- You can adjust the ROOM 2 volume.

■When selecting the tone (bass and treble).

- The tone level can be adjusted within the range of -10 ~ +10 dB.
- In general, we recommend the bass and treble to be adjusted to 0 dB (flat level).
- Extreme settings at high volume may damage your speakers.

4. Start play on the component related to the ROOM 2 source.

■Notes:

- Even when this receiver enters the standby mode, in such a case that the POWER ON/STANDBY button lights up blue (and "MULTI" lights up still) as it does in the operating mode, meaning only the ROOM 2 circuitry operates, the ROOM 2 source can be played independently.
- When you do not use the ROOM 2 function, turn it off to save electricity.

Listening to ROOM 3 source

- You cannot select a different source for ROOM 3 and can play only the audio signals from the same source that you select for main room.

1. Press the ROOM 3 button to enter the ROOM 3 mode.



- ROOM 3 ~ is displayed for several seconds.
- When the ROOM 3 mode disappears, press the ROOM 3 button again.

2. Set the ROOM 3 mode as desired.

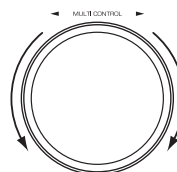

ON : To turn on the ROOM 3 function and to play the

↑ same source that you select for main room.

OFF : To turn it off.



OSD Menu Settings

- The OSD (On-Screen Display) menu is a setting menu that is displayed on the monitor TV and allows you to perform the setup procedures easily. In most situations, you will only need to set this once during the installation and layout of your home theater, and it rarely needs to be changed later.







The OSD menu consists of 7 main menus ; System Setup, Speaker/Listening Setup, Input Setup, Sound Parameter, Multi Room Configuration, Advanced Configuration and Quick Audio Reference/Adjustment.

These menus are then divided up into various sub-menus.

■ Navigating through the OSD menu

- The explanations here assume you are using the buttons on the remote control when performing the OSD menu operation. However, you can use the buttons on the front panel as well.

The buttons on the front panel correspond to those on the remote control as shown below.

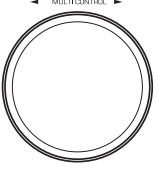
Button on the remote control				
Button on the front panel				

1. Turn the menu screen on.

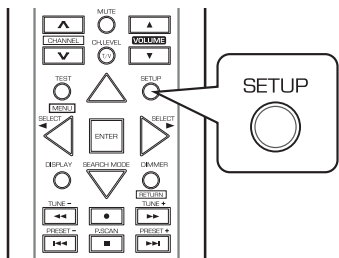

- The main menu will be shown.
- To turn the menu screen off, press this button again.

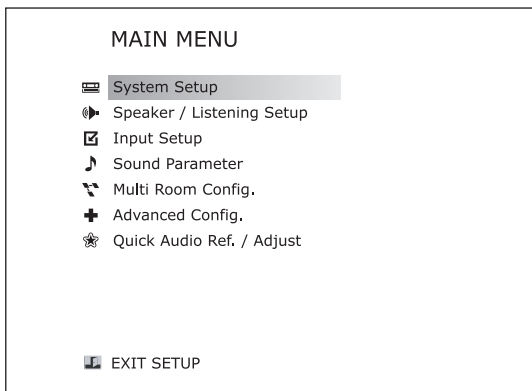

2. Select the desired menu using the CURSOR UP(▲)/DOWN(▼) buttons.

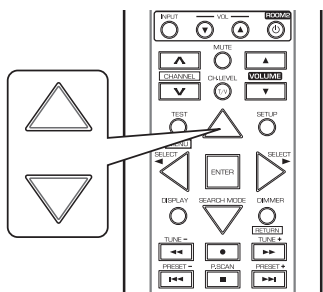



3. Confirm your selection.

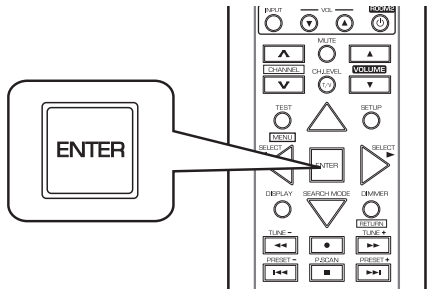

■ When selecting the System Setup

SYSTEM SETUP

- ⚙️ AMP Assign ◀ SB <-> R2 ▶
- 🔊 Subwoofer Mode ◀ Normal ▶
- 📺 Monitor Output ◀ HDMI ▶
- 📺 Video Scaling ◀ Auto ▶
- 📺 HDMI Audio Output ◀ Off ▶
- ⚡ Momentary OSD ◀ --- ▶

🏠 RETURN TO MAIN MENU

58

ENGLISH

■ When selecting the Speaker/Listening Setup

SPEAKER / LISTENING SETUP

- ▶ Auto Setup Trinnov Optimizer
- 🔊 Speaker Config.
- 📏 X-Over Frequency
- 🔊 Speaker Distance
- 🔊 Speaker Level Trim

🏠 RETURN TO MAIN MENU

61

■ When selecting the Input Setup

INPUT SETUP

- 📺 Video1
- 📺 Video2
- 📺 Video3
- 📺 Video4
- 📺 Video5

➡ GO TO NEXT(2/2) PAGE

🏠 RETURN TO MAIN MENU

69

■ When selecting the Sound Parameter

SOUND PARAMETER

- 🌙 Night Mode / DRC
- 🔊 DOLBY / DTS ◀ 0.0 (Off) ▶
- 🔊 Dolby TrueHD ◀ Off ▶
- 🎵 Dolby PL II Music
- 📏 Panorama ◀ Off ▶
- 📏 Center Width ◀ 3 ▶
- 📏 Dimension ◀ 0 ▶
- 🔊 Dolby VS
- 🔊 Reference ◀ 2 Speaker ▶
- 🔊 Wide ◀ 2 Speaker ▶
- 🎧 Dolby Headphone ◀ Movie ▶

🏠 RETURN TO MAIN MENU

75

■ When selecting the Multi Room Configuration

MULTI ROOM CONFIG.

- 🏠 Room 2 ◀ Off ▶
- Input ◀ Main ▶
- Volume ◀ -30 dB ▶
- Tone
- Bass ◀ 0 dB ▶
- Treble ◀ 0 dB ▶
- 🏠 Room 3 ◀ Off ▶

🏠 RETURN TO MAIN MENU

77

■ When selecting the Advanced Configuration

ADVANCED CONFIG.

- 📺 Monitor Aspect ◀ Standard ▶
- 📺 Video Fomat ◀ NTSC ▶
- 📺 Noise Reduction ◀ Off ▶
- 🔊 Video Enhancer ◀ Off ▶

🏠 RETURN TO MAIN MENU

79

■ When selecting the Quick Audio Reference/Adjustment

QUICK AUDIO REFERENCE / ADJUSTMENT

- 🔊 Trinnov Position ◀ None ▶
- Trinnov Room EQ ◀ None ▶
- Trinnov Spatial Mode ◀ None ▶
- Trinnov Remapping ◀ Cinema ▶
- 🔊 Center Level ◀ 0 dB ▶
- 🔊 Subwoofer Level ◀ 0 dB ▶
- 🔊 Tone Control ◀ Off ▶
- Bass ◀ 0 dB ▶
- Treble ◀ 0 dB ▶

🏠 RETURN TO MAIN MENU

81

- For the setting details, see page in ➡.
- Adjust the setting(s) in each setting category to your preference.
- When the SETUP button is pressed on a sub-menu, the menu screen will be turned off.
- To return to the previous menu, press the CURSOR UP(▲)/DOWN(▼) buttons to select "RETURN TO ~", then press the ENTER button.





SETTING THE SYSTEM SETUP

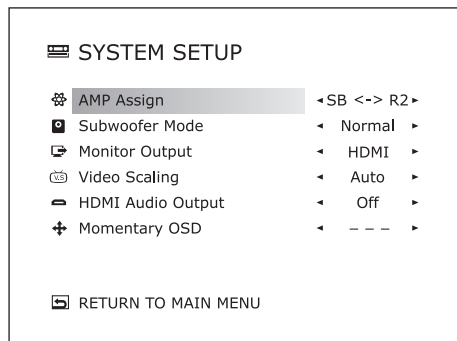

- AMP Assign : To assign the surround back channels' power amplifier correctly depending on how to use the speakers.
- Subwoofer Mode : To select the desired subwoofer mode.
- Monitor Output : To select the MONITOR OUT from which the video signals are output.
- Video Scaling : To set the resolution of video signals to be output to match that of your TV.
- HDMI Audio Output : To output the digital audio signals from the HDMI MONITOR OUT.

■ Note:

- The Momentary OSD is not available for this receiver.

1. Press the CURSOR UP(▲)/DOWN(▼) buttons to select the desired item.

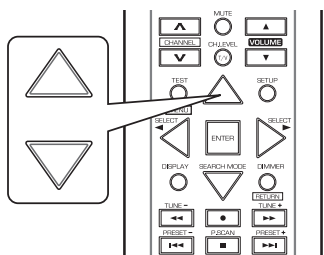

2. Press the CURSOR LEFT(◀)/RIGHT(▶) buttons to set the selected item as desired.

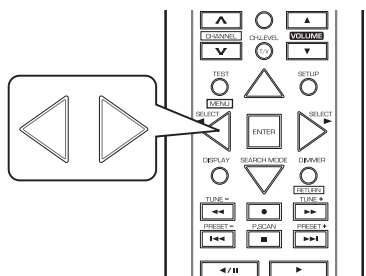

When selecting the AMP Assign

- The surround back channels' power amplifier can drive the surround back speakers, the ROOM 2 speakers or the front bi-amp capable speakers. Depending on how to use the speakers, you should assign the power amplifier correctly. (For details, refer to "CONNECTING SPEAKERS" on page 11 and "CONNECTING ROOM 2 AND ROOM 3 OUTS" on page 13.)

- SB <-> R2 : When connecting this receiver to the surround back speakers and the ROOM 2 speakers both, the power amplifier automatically drives the surround back speakers or the ROOM 2 speakers depending on whether the ROOM 2 function is turned off or on.
- BI - AMP : To drive the front bi-amp capable speakers when connecting the FRONT and the SURROUND BACK/MULTI channels to them.
- SURR BACK : To drive the surround back speakers when connecting the SURROUND BACK/MULTI channels to them.
- ROOM 2 : To drive the ROOM 2 speakers when connecting the ROOM 2 channels to them. ("▶ MULTI" lights up.)

■ Note :

- When you change the AMP ASSIGN setting, you should perform the Auto Setup Trinnov Optimizer to use it correctly. (For details, refer to "When selecting the Auto Setup Trinnov Optimizer" on page 61.)



Continued

When selecting the Subwoofer Mode

- "SW Plus + " mode is valid only when "Front" is set to "Full" and "Subwoofer" is set to "Yes". (For details, refer to "SETTING THE SPEAKER/ LISTENING SETUP" on page 61.)

Normal : When the low frequency signals of channels set to "Full" are reproduced from those channels only. In this mode, the low frequency signals that are reproduced from the subwoofer channel is only the low frequency signals of LFE (from the multi-channel sources that contains LFE(Low Frequency Effects) channel, also called the ".1" channel) and the channels set to the setting value other than "Full".

SW Plus + : When the low frequency signals of channels set to "Full" are reproduced simultaneously from those channels and the subwoofer channel.

In this mode, the low frequency range expands more uniformly through the room, but depending on the size and shape of the room, interference may result in a decrease of the actual volume of the low frequency range.

When selecting the Monitor Output

- You should select the MONITOR OUT which is connected to your TV.
- Depending on the Video Mode setting, this unit can convert video signals and output them from the MONITOR OUT to which the Monitor Output is set. (For details, refer to "Video conversion" on page 7.)

■ Note:

- If no picture or no OSD menu will be displayed on your TV, be sure to set the Monitor Output and the Video Mode correctly.

→ HDMI : The video signals are output from the HDMI MONITOR OUT only.



Component : The video signals are output from the COMPONENT MONITOR OUTs only.



→ SC-Video : The video signals are output from the (composite) VIDEO, S-VIDEO and the COMPONENT MONITOR OUTs.

When selecting the Video Scaling

- When the Monitor Output is set to "HDMI" or "Component", you should set the resolution of video signals to be output from the HDMI MONITOR OUT or the COMPONENT MONITOR OUTs to match that of your TV. (For details on the resolution compatible with your TV, refer to the operating instructions of your TV.)
- When the HDMI MONITOR OUT is connected to an HDMI-compatible TV, the TV reports to this unit what resolutions it supports. Therefore, if you set the Video Scaling to "Auto", this unit outputs the video signals of the optimum resolution acceptable for your TV.

■ Notes :

- If the resolutions of the video signals which are output from the HDMI MONITOR OUT or the COMPONENT MONITOR OUTs and your TV are not matched, the picture is not clear, natural or displayed.
- Some of HDMI-compatible TVs may not report their resolution information. In this case, if you set the Video Scaling to "Auto", the 480p video signals will be output from the HDMI MONITOR OUT.
- When the Monitor Output is set to "SC-Video", the 480i video signals will be output from each MONITOR OUT regardless of the Video Scaling setting.
- When the Monitor Output is set to "HDMI", if Video Scaling is set to "Bypass" and the composite video signals or the S-Video signals are input, the 480p video signals will be output from the HDMI MONITOR OUT.
- When the Monitor Output is set to "Component", if the Video Scaling is set to "Auto", the video signals will be output at the same resolution that they are input.

→ Auto : To convert the video signals being input to the video signals of the highest resolution acceptable for TV and to output them from the HDMI MONITOR OUT.



Bypass : To output the video signals at the same resolution that they are input, with no conversion.



480p(576p) : To convert the video signals to 480p(NTSC)(or 576p(PAL)) video signals and to output them.



720p : To convert the video signals to 720p video signals and to output them.



1080i : To convert the video signals to 1080i video signals and to output them.



→ 1080p : To convert the video signals to 1080p video signals and to output them.

Continued

When selecting the HDMI Audio Output

- The HDMI connection can carry uncompressed digital video signals and digital audio signals.
Depending on whether the digital audio signals are output from the HDMI MONITOR OUT of this receiver or not, you should set the HDMI Audio Output correctly.
- When the HDMI Audio Output is set to On, this unit converts the analog audio signals (which are input into the (analog) AUDIO INs) or the digital audio signals (which are input into the HDMI IN, the OPTICAL or the COAXIAL DIGITAL IN) to the PCM 2 channel signals and outputs them from the HDMI MONITOR OUT depending on the Audio Mode setting. (For details, refer to "When selecting the Audio Mode" on page 71.)

Off : Not to output the digital audio signals from the HDMI MONITOR OUT of this receiver, meaning these signals are heard
↓ from the speakers connected to this receiver.

On : To output PCM 2 channel digital audio signals depending on the Audio Mode setting, meaning these signals are heard
↑ from the speakers of your TV.

■ Notes :

- Even when the HDMI Audio Output is set to On, if the OSD menu is displayed or the pure audio function is activated, the digital audio signals cannot be output from the HDMI MONITOR OUT.
- When the HDMI Audio Output is set to On, no sound will be heard from the speakers connected to this receiver (except ROOM 2 speakers) even though any input source is selected.



SETTING THE SPEAKER / LISTENING SETUP

- After you have installed this receiver and connected all the components, you should adjust the speaker settings for the optimum sound acoustics according to your environment and speaker layout.
- Even when you change speakers, speaker positions, or the layout of your listening environment, you should adjust the speaker settings, too..

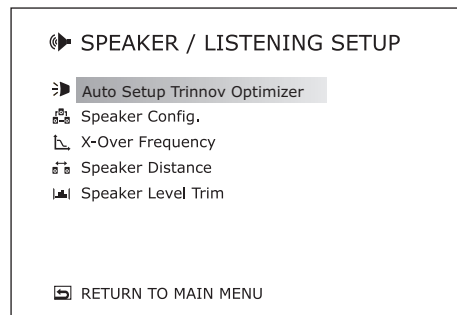

- Auto Setup Trinnov Optimizer : To set the speaker setup and speaker level automatically.
- Speaker Configuration : To adjust the speakers depending on whether they are connected or not.
- Crossover Frequency : To select the desired crossover frequency.
- Speaker Distance: To select the distance between the listening position and each speaker to set the delay time automatically for optimum surround playback.
- Speaker Level Trim : To adjust speaker level or LFE level.

When selecting the Auto Setup Trinnov Optimizer

- Auto Setup Trinnov Optimizer lets you avoid troublesome listening-based speaker setup and achieve good surround. Auto Setup Trinnov Optimizer has the feature that provides the optimum listening environment at up to three listening positions, where you often sit depending on your tastes or program source, etc. You should connect the supplied microphone to the Trinnov Mic connector so that this receiver can analyze the information from a series of test tones emitted from speakers at listening position and can adjust the configuration, crossover frequency, distance, sound level and frequency response of each speaker automatically.
- If you want to personalize your speaker setup and speaker level trim by making the settings manually, perform "When selecting the Speaker Configuration" on page 64, "When selecting the Crossover Frequency" on page 65, "When selecting the Speaker Distance" on page 66 and "When selecting the Speaker Level Trim" on page 67.
- After the Auto Setup Trinnov Optimizer has been completed, you can set the Trinnov settings as desired. (For details, refer to "SETTING THE INPUT SETUP" on page 69.)
- Manufactured under license from Trinnov Audio. US and worldwide patents issued and pending. Trinnov is a trademark of Trinnov Audio. This product contains one or more programs protected under international and U.S. copyright laws as unpublished works. They are confidential and proprietary to Trinnov Audio. Their reproduction or disclosure, in whole or in part, or the production of derivative works therefrom without the express permission of Trinnov Audio is prohibited. Copyright 2003-2008 Trinnov Audio. All rights reserved.

■ Preparations

- ①. Check that the speakers are securely connected to this receiver.
 - If your subwoofer has adjustable volume and crossover frequency, set the volume halfway and set the crossover frequency to the maximum or the low pass filter off.
- ②. Connect the supplied microphone to the Trinnov Mic connector on the rear panel.(For details, refer to "CONNECTING MICROPHONE" on page 14.)

■ Notes :

- Because the microphone for Auto Setup is especially designed by Trinnov for use with this receiver, to use the auto setup function, do not use a microphone other than the one supplied with this receiver.
- After you have completed the auto setup procedure, disconnect the microphone.

1. Place the microphone on a flat level surface at the listening position facing its "FRONT" side marked with the red dot toward your AV system.

- If possible, use a tripod, etc. to attach the microphone at the same height as your ears would be when you are seated in your listening position.
- Ensure there are no obstacles between the speakers and the microphone.





ENGLISH

Continued

- Press the CURSOR UP(▲)/DOWN(▼) buttons to select the Auto Setup Trinnov Optimizer, then press the ENTER button.

➤ AUTO SETUP Trinnov Optimizer

Calibrate

- Position 1
- Position 2
- Position 3

Results

- Position 1
- Position 2
- Position 3

RETURN TO SETUP MENU

When calibrating at a position

When checking the results memorized into the memory of the position

- Press the CURSOR UP(▲)/DOWN(▼) buttons to select the desired position to calibrate, then press the ENTER button.

➤ AUTO SETUP Trinnov Optimizer

Place Microphone at

Listening Position

- ear height
- Aim red dot to the front of desired acoustic image

START CALIBRATION

RETURN TO SETUP MENU

- After the Auto Setup Trinnov Optimizer has been completed at a position, when you want to check its results, select the desired of positions for results. (For details on results, refer to the following step 5.)

- Press the CURSOR UP(▲)/DOWN(▼) buttons to select "START CALIBRATION", then press the ENTER button.

When the measurement has been completed.

➤ AUTO SETUP Trinnov Optimizer

Units	H Angle deg	V Angle deg	DIST Meter
Front L	5	-27	3.01 m
Center	2	2	10.21 m
Front R	-6	32	8.00 m
Surround R	12	116	10.00 m
Surround Back / Multi R	17	148	10.00 m
Surround Back / Multi L	-	-	-
Surround L	-	-	10.00 m
SubWoofer	-	-	10.00 m

COMPUTATION START

CANCEL

- If loud test tones are output successively and a series of measurement procedure has been completed, the results on horizontal angle, vertical angle and distance of each speaker are displayed.
- If there may be a problem with speaker or microphone connection, error message will be displayed. In this case, turn off the power, check the connection and then retry the Auto Setup Trinnov Optimizer.
- If you are not satisfied with the results, press the CURSOR UP(▲)/DOWN(▼) buttons to select "CANCEL", then press the ENTER button. In such a case, you can retry the auto setup procedure or personalize your speaker setup and speaker level by making the settings manually. (For details, refer to "When selecting the Speaker Configuration" on page 64, "When selecting the Crossover Frequency" on page 65, "When selecting the Speaker Distance" on page 66 and "When selecting the Speaker Level Trim" on page 67.)

Notes :

- Because the test tones are loud, ensure there no infants or small children in the room.
- For best results, ensure the room is as quiet as possible during the auto setup procedure. If there is too much ambient noise, the results may not be satisfactory.





5. Press the CURSOR UP(▲)/DOWN(▼) buttons to select "COMPUTATION START", then press the ENTER button.

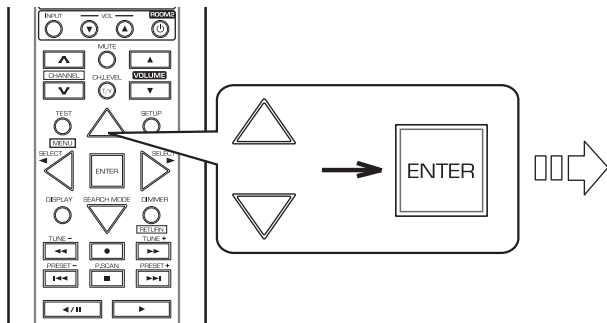

When the computation has been completed.

▶ AUTO SETUP Trinnov Optimizer

Units	H Angle deg	V Angle deg	DIST Meter
Front L	5	-27	3.01 m
Center	2	2	10.21 m
Front R	-6	32	8.00 m
Surround R	12	116	10.00 m
Surround Back / Multi R	17	148	10.00 m
Surround Back / Multi L	-	-	-
Surround L	-	-	10.00 m
SubWoofer	-	-	10.00 m

▶ NEXT

- If a series of computation procedure has been completed, the results are displayed.
- To check the next or the previous results, press the CURSOR UP(▲)/DOWN(▼) buttons to select "NEXT" or "PREVIOUS", then press the ENTER button.
- To stop the computation procedure while performing it, turn the power off, then results cannot be memorized.



■ Note:

- Depending on the number of speakers to be calibrated, it may take up to 25 minutes to complete the computation procedure.

▶ AUTO SETUP Trinnov Optimizer

	-6dB point	Level	Deley
Front L	40 Hz	1.0 dB	1.02 ms
Center	80 Hz	-1.0 dB	1.02 ms
Front R	40 Hz	0.0 dB	10.01 m
Surround R	80 Hz	0.0 dB	8.57 m
Surround Back / Multi R	80 Hz	3.0 dB	3.0 m
Surround Back / Multi L	-	-	--
Surround L	80 Hz	-3.0 dB	3.14 m
SubWoofer	20 Hz	-3.0 dB	3.02 m

▶ FINISH (Power will be Off)

▶ PREVIOUS

6. To finish the Auto Setup Trinnov Optimizer, press the CURSOR UP(▲)/DOWN(▼) buttons to select "FINISH ~" at the next results, then press the ENTER button.

- Then the power is turned off and the results are memorized into the memory of the current listening position.

7. To perform the Auto Setup Trinnov Optimizer at other listening position, repeat the above the steps 1 ~ 6.





Continued

When selecting the Speaker Configuration

- Only when the Trinnov Position is set to "None", you can set the Speaker Configuration manually. (For details, refer to "When selecting the Trinnov Position" on page 72.)

1. Press the CURSOR UP(▲)/DOWN(▼) buttons to select the Speaker Configuration, then press the ENTER button.

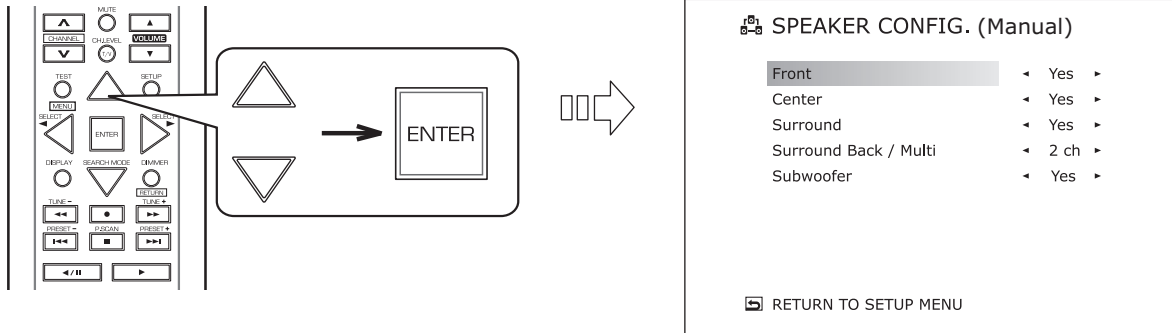

2. Press the CURSOR UP(▲)/DOWN(▼) buttons to select the desired speaker.

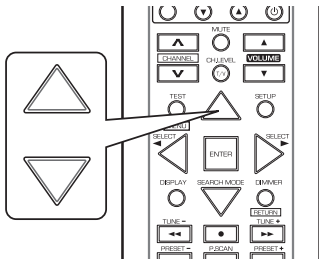

3. Press the CURSOR LEFT(◀)/RIGHT(▶) buttons to set the selected speaker as desired.

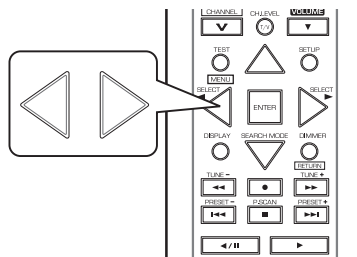

Yes/No: Select the desired depending on whether the speakers are connected or not.

2 ch/1 ch: Select the desired depending on the number of speakers connected to SURROUND BACK/ MULTI channels.

■ Notes :

- When speakers are not set to "No", you should set their distances from listening position and crossover frequencies according to their frequency characteristics. (For details, refer to "When selecting the Crossover Frequency" on page 65 and "When selecting the Speaker Distance" on page 66.)
- When the "Surround" is set to "No", "Surround Back/Multi" cannot be set to "2 ch" or "1ch".
- When the surround back channels' power amplifier is assigned to "BI-AMP" or "Room 2", the "Surround Back/Multi" cannot be selected. (For details, refer to "When selecting the AMP Assign" on page 58.)

4. Repeat the above steps 2 and 3 until the speakers are all set as desired.





When selecting the Crossover Frequency

- Only when the Trinnov Position is set to "None", you can set the Crossover Frequency manually. (For details, refer to "When selecting the Trinnov Position" on page 72.)
- Set the crossover frequency according to the frequency characteristics of the speakers connected.
(For details on the frequency characteristics, refer to the operating instructions of the speakers.)
- If the frequency range of your speaker is 100 Hz ~ 20 kHz, the crossover frequency should be set to 100 Hz (or slightly higher).
- The low frequencies below the crossover frequency are to output from subwoofer or the speakers which are set to "Full" (when not using a subwoofer).

1. Press the CURSOR UP(▲)/DOWN(▼) buttons to select the Crossover Frequency, then press the ENTER button.

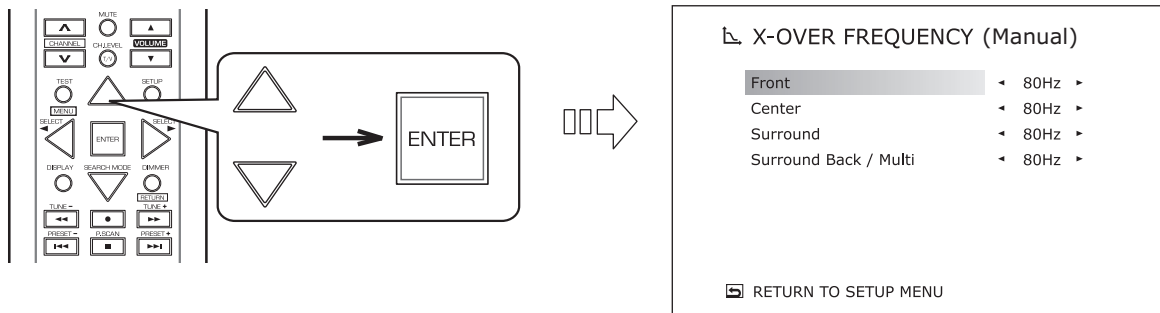

2. Press the CURSOR UP(▲)/DOWN(▼) buttons to select the desired speaker.

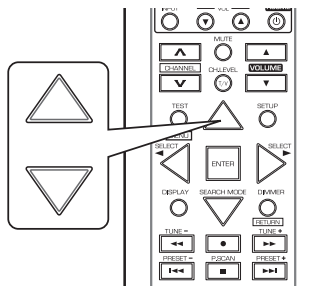

■ Note :

- You cannot select the subwoofer and the speakers set to "No".

3. Press the CURSOR LEFT(◀)/RIGHT(▶) buttons to set the crossover frequency as desired.

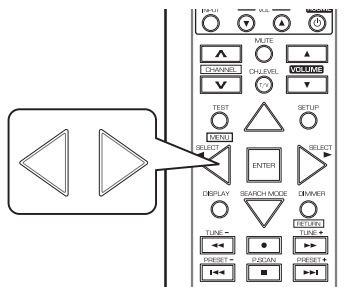

- You can adjust the crossover frequency within the range of 40 ~ 250 Hz.
- Select "Full" when the selected speaker can fully reproduce the low frequencies below 40 Hz.

4. Repeat the above steps 2 and 3 until the crossover frequencies are all set as desired.





When selecting the Speaker Distance

- Only when the Trinnov Position is set to "None", you can set the Speaker Distance manually. (For details, refer to "When selecting the Trinnov Position" on page 72.)

1. Press the CURSOR UP(▲)/DOWN(▼) buttons to select the Speaker Distance, then press the ENTER button.

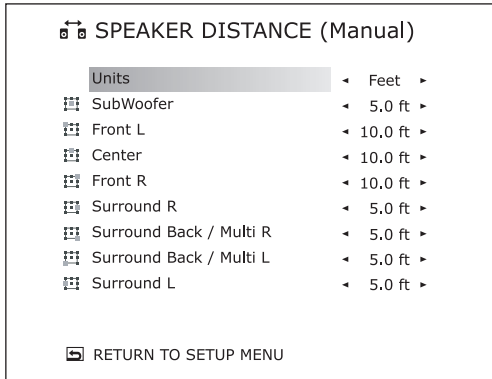
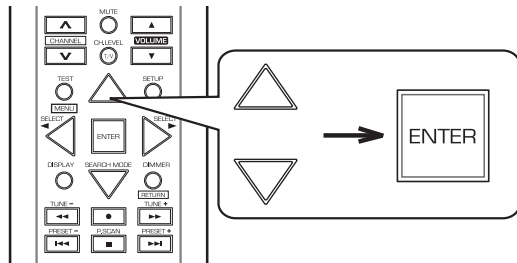

2. Press the CURSOR UP(▲)/DOWN(▼) buttons to select the desired item.

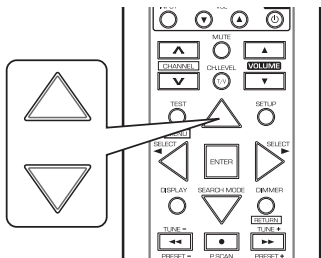

■ Note :

- You cannot select the subwoofer and the speakers set to "No".

3. Press the CURSOR LEFT(◀)/RIGHT(▶) buttons to set the selected item as desired.

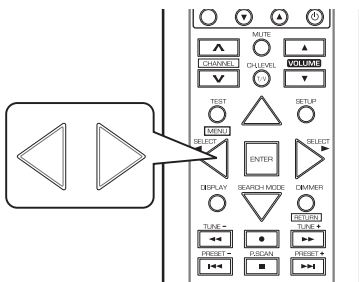

■ When selecting the desired unit

- You can select either Meters or Feet.
- Once a unit is selected, the distances are automatically changed in the selected unit.

■ When setting the distance

- You can set the distance within the range of 0.1 ~ 9.0 meters in 0.1 meter intervals (or 0.5 ~ 30 feet in 0.5 feet intervals).

4. Repeat the above steps 2 and 3 until the distances are all set as desired.

■ About the speaker distance

When enjoying multi-channel surround playback with Dolby Digital and DTS sources, etc., it is ideal that the center, surround, surround back and subwoofer speakers should be the same distance from the main listening position as the front speakers. By entering the distance between the listening position and each speaker, the delay times of center, surround, surround back and subwoofer speakers are automatically adjusted to create an ideal listening environment virtually as if the center, surround, surround back and subwoofer speakers were at their ideal locations respectively.





When selecting the Speaker Level Trim

- Only when the Trinnov Position is set to "None", you can set the Speaker Level Trim manually. (For details, refer to "When selecting the Trinnov Position" on page 72.)

1. Press the CURSOR UP(▲)/DOWN(▼) buttons to select the Speaker Level Trim, then press the ENTER button.

Memory mode

SPEAKER LEVEL TRIM (Manual)		
Mode	◀ Trim ▶	
Front L	◀ 0 dB ▶	
Center	◀ 0 dB ▶	
Front R	◀ 0 dB ▶	
Surround R	◀ 0 dB ▶	
Surround Back / Multi R	◀ 0 dB ▶	
Surround Back / Multi L	◀ 0 dB ▶	
Surround L	◀ 0 dB ▶	
SubWoofer	◀ 0 dB ▶	
LFE	◀ 0 dB ▶	
RETURN TO SETUP MENU		

■ Adjusting the current channel level

- You can adjust the current channel levels as desired. These adjusted levels are just memorized into user's memory("Trim"), not into preset memory("Ref 1", "Ref 2").
- After adjusting each channel level with test tone, adjust the channel levels either according to the program sources or to suit your tastes.(For details, refer to "Adjusting each channel level with test tone" on page 40.)

2. Press the CURSOR UP(▲)/DOWN(▼) buttons to select the desired channel.

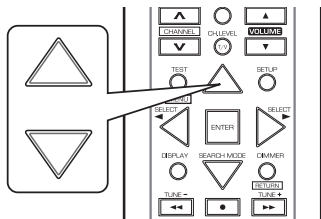

■ Note :

- Depending on the speaker settings("No", etc.), some channels cannot be selected.

□ When adjusting the LFE level

- ①. Press the CURSOR UP(▲)/DOWN(▼) buttons to select the LFE, then press the ENTER button.

LFE LFE LEVEL ADJUST

Dolby Digital	◀ 0 dB ▶
DTS	◀ 0 dB ▶
Dolby TrueHD	◀ 0 dB ▶
DTS HD	◀ 0 dB ▶

- ②. Press the CURSOR UP(▲)/DOWN(▼) buttons to select the desired program source.

3. Press the CURSOR LEFT(◀)/RIGHT(▶) buttons to adjust the level of the selected channel or program source's LFE as desired.

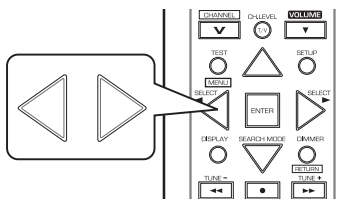

- The LFE level can be adjusted within the range of -10 ~ 0 dB and other channel levels within the range of -15 ~ +15 dB
- In general, we recommend the LFE level to be adjusted to 0 dB.(However, the recommended LFE level for some early DTS software is -10 dB.) If the recommended levels seem too high, lower setting as necessary.

4. Repeat the above steps 2 and 3 to adjust each channel level.





■ Memorizing the adjusted channel levels

- You can memorize the adjusted channel levels into preset memory("Ref 1", "Ref 2") and recall the memorized whenever you want.

- After performing the steps 2~4 in "Adjusting the current channel level" procedure on page 67, press the CURSOR UP(▲)/DOWN(▼) buttons to select a channel (, not the Mode (memory mode) and the LFE), then press the ENTER button.

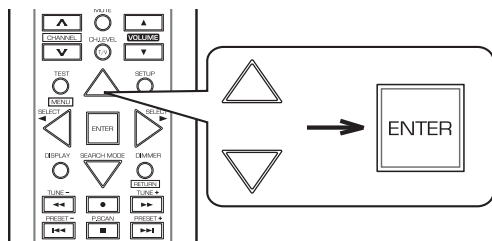

- Press the CURSOR LEFT(◀)/RIGHT(▶) buttons to select the desired preset memory, then press the ENTER button.

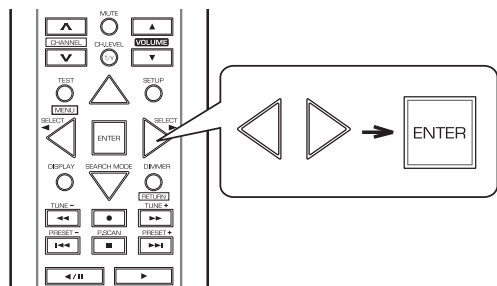

- Each time the CURSOR LEFT(◀) or RIGHT(▶) button is pressed, "Ref 1" or "Ref 2" is selected.
- The adjusted channel levels have now been memorized into the selected memory.

■ Recalling the memorized channel levels

- Press the CURSOR UP(▲)/DOWN(▼) buttons to select the Mode(memory mode).

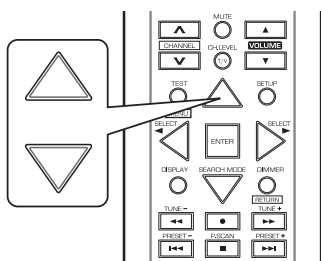

- "Trim" may be displayed instead of "Ref 1" or "Ref 2".

- Press the CURSOR LEFT(◀)/RIGHT(▶) buttons to select the desired one of Ref 1 and Ref 2.

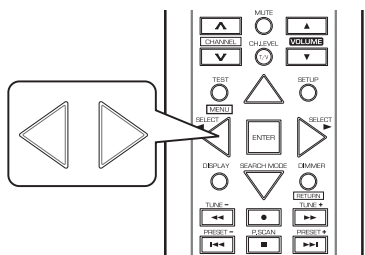

- Then the channel levels memorized into the selected preset memory are recalled.





SETTING THE INPUT SETUP

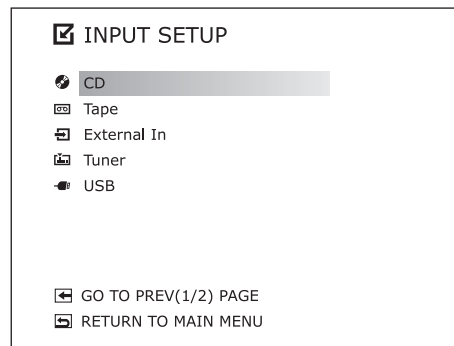
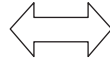
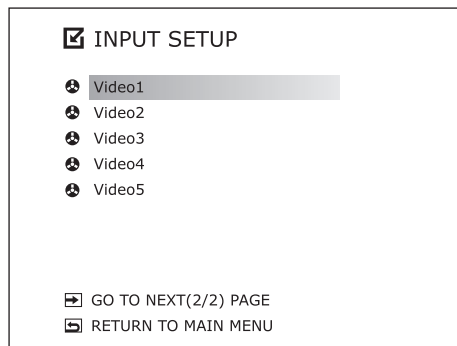

ENGLISH

• The input setup menu allows you to make the various settings depending on how to use the input sources connected to this receiver.

■ When moving to the next or the previous page

• Press the CURSOR UP(▲)/DOWN(▼) buttons to select "GO TO NEXT (or PREV) ~", then press the ENTER button.

When selecting the items other than NAME

1. Press the CURSOR UP(▲)/DOWN(▼) buttons to select the desired input source, then press the ENTER button.

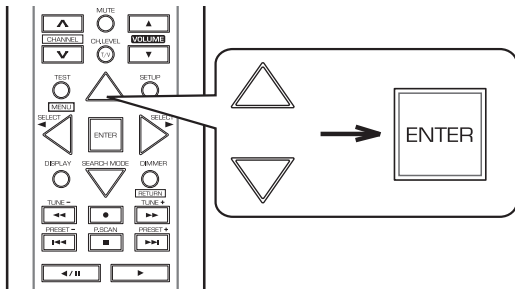

Example: When selecting the VIDEO 1

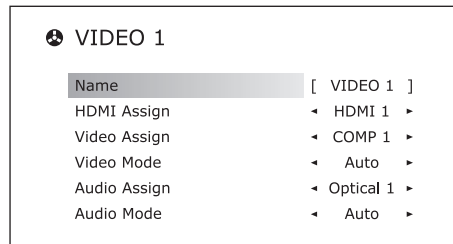

Example: When selecting the page 2

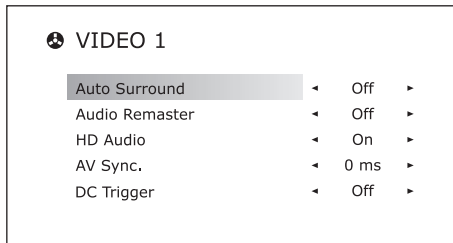

Example: When selecting the page 3

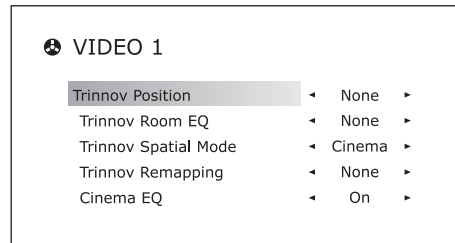

2. Press the CURSOR UP(▲)/DOWN(▼) buttons to select the desired item.

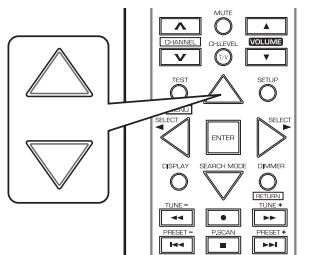

■ Note :

• Depending on the input source, some items other than DC Trigger cannot be selected.





Continued

3. Press the CURSOR LEFT(◀)/RIGHT(▶) buttons to set the selected item as desired.

ENGLISH

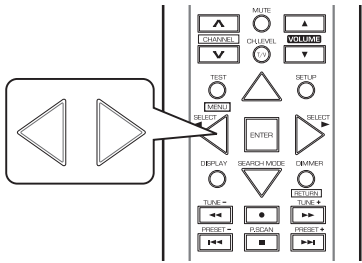

When selecting the HDMI Assign

- You should assign the connected HDMI INs to the desired of VIDEO 1 ~ VIDEO 5.
(For details, refer to "CONNECTING VIDEO COMPONENTS" on pages 6 ~ 8.)
- You can select the desired of HDMI 1 ~ HDMI 4.

■ **Note :**

- In such a case that a HDMI IN is assigned to two input sources or more, when these input sources are selected, the uncompressed digital video signals (and digital audio signals when the HDMI Audio Output is set to On) input into the same HDMI IN can be output from the HDMI MONITOR OUT of this receiver.

When selecting the Video Assign

- You should assign the connected COMPONENT VIDEO INs to the desired of VIDEO 1 ~ 5.
(For details, refer to "CONNECTING VIDEO COMPONENTS" on pages 6 ~ 8.)
- You can select the desired of COMP 1 ~ 3.

■ **Note :**

- In such a case that a COMPONENT VIDEO IN is assigned to two input sources or more, when these input sources are selected, the component video signals can be viewed from the same COMPONENT VIDEO IN.

When selecting the Video Mode

- You can select the video input signal to be output from the MONITOR OUTs depending on the Monitor Output settings.
(For details, refer to "When selecting the Monitor Output" on page 59.)

- Auto : When there are multiple video input signals, the video input signals are detected and the video input signal to be output from the MONITOR OUTs is selected automatically in the priority order of them :
 ↓ "HDMI" > "COMPONENT" > "S-VIDEO" > "(composite) VIDEO"
 HDMI : The signal that is input into the HDMI IN connector is always played. The HDMI video input signal is output from the
 ↓ HDMI MONITOR OUT only.
 Component : The signals that are input into the COMPONENT IN jacks are always played.
 ↓ The component video signals are converted and output from the MONITOR OUTs.
 S-Video : The signal that is input into the S-VIDEO IN jack is always played.
 ↓ The S-Video signal is converted and output from the MONITOR OUTs.
 → Composite : The signal that is input into the (composite) VIDEO IN jack is always played.
 ↓ The composite video signal is converted and output from the MONITOR OUTs.

- For details on the video input signal to be output, refer to "Video conversion" on page 7.

When selecting the Audio Assign

- You should assign the connected DIGITAL INs to the desired of CD and VIDEO 1 ~ VIDEO 5.
(For details, refer to "CONNECTING DIGITAL INs AND OUT" on page 10.)
- You can select the desired of Optical 1 ~ 5 and Coaxial 1 ~ 2.

■ **Note :**

- In such a case that a DIGITAL IN is assigned to two input sources or more, when these input sources are selected, the digital audio signals can be heard from the same DIGITAL IN.



Continued

When selecting the Audio Mode

- You should select the audio input signal to be played.

■ Notes :

- Be sure to set the Audio Mode to the audio input which is connected and assigned to the selected input source.
- When the HDMI Audio Output is set to On, no sound will be heard from the speakers connected to this receiver (except ROOM 2 speakers).
- When the HDMI Audio Output is set to On to play the audio signal on your TV, depending on the Audio Mode setting, this unit can convert the corresponding audio signal to the PCM 2 channel signals and output them from the HDMI MONITOR OUT. (For details, refer to "Audio conversion" on page 8.)
- When the Audio Mode is set to HDMI, you should connect the HDMI INs and set the HDMI Assign correctly. If not, the "HDMI" indicator flickers on the unit's display and no sound will be heard.
- When the Audio Mode is set to Digital, you should connect the DIGITAL INs and set the Audio Assign correctly. If not, the "DIG." indicator flickers on the unit's display and no sound will be heard.

- Auto : When there are multiple audio input signals, the audio input signals are detected and the audio input signal to be played is selected automatically in the priority order of them :
 ↓
 HDMI audio > Digital audio > Analog audio
 HDMI : The signal that is input into the HDMI IN is always played.
 ↓
 Digital : The signal that is input into the OPTICAL or the COAXIAL DIGITAL IN is always played.
 ↓
 → Analog : The signal that is input into the analog AUDIO INs is always played.

When selecting the Auto Surround

- Depending on how to select a surround mode, you can select the auto surround mode or the manual surround mode.

Off : You can select the desired of different surround modes selectable for the signal being input with (Manual surround mode) using the MULTI CONTROL knob or the SURROUND MODE UP/DOWN (>/<) buttons.
 ↓
 (For details, refer to "When selecting the manual surround mode with pressing the SURROUND MODE button on the front panel" on page 39.)

On : The optimum surround mode will be automatically selected depending on the signal format being input. (Auto surround mode)

■ Notes :

- Even when the auto surround mode is selected and the same type of digital signal format is being input, the optimum surround mode may vary depending on whether the speaker is set to "No" or not.
- When the auto surround mode is selected, the surround modes other than the optimum surround mode cannot be selected.

When selecting the Audio Remaster

- The remastering processes the input signal digitally and converts its digital sampling frequency to twice the current frequency (88.2/96 kHz or 176.4/192 kHz) for a more detailed sound reproduction.

Off : To turn off the remastering function ("RE-MASTERING" goes off).

↓

On : To turn it on ("RE-MASTERING" lights up)

■ Notes :

- The remastering function has an effect on the digital input signal from only the 88.2/96 kHz PCM (2 channel) source or lower.
- When the remastering function is activated, the stereo mode is automatically selected.

Continued

When selecting the HD Audio

- When the source components that cannot support the HD audio signal format (such as Dolby Digital Plus, Dolby TrueHD, DTS-HD High Resolution Audio, DTS-HD Master Audio, etc.) are connected to the HDMI IN of this receiver, some components may not output any audio signals from its HDMI OUT. In this case, you should set the HD Audio to Off to play the audio signals other than the HD audio signals. (For details on the playable audio signal format, refer to the operating instructions of the source component.)

On : To play the audio signals (including the HD audio signals).



Off : To play the audio signals other than the HD audio signals.

When selecting the AV Sync

- There may be a slight time delay between the video and audio signals in case that some video playback equipments may process the video signals later than the audio signals due to signal processing procedure, etc.. Should this happen, you can adjust the time delay of audio signals to synchronize the sound with the picture.
- The time delay can be adjusted within the range of 0 ~ 200 msec.

When selecting the DC Trigger

- To turn on the component connected to the DC TRIGGER OUT jack when the input source is selected, you should set the DC Trigger to On for this input source.

Off : To turn off the DC trigger function.



On: To turn it on.

- For details, refer to "CONNECTING DC TRIGGER OUT" on page 15.

When selecting the Trinnov Position

- You can select the desired of the listening positions at which the Auto Setup Trinnov Optimizer has been completed depending on your tastes or program source, etc.
- When you want to listen in the settings you make manually on the Speaker Configuration, the Crossover Frequency, the Speaker Distance and the Speaker Level Trim menus, you should set the Trinnov Position to "None".

■ Note :

- The Trinnov Room EQ, the Trinnov Spatial Mode and the Trinnov Remapping settings can be set when the Trinnov Position is not set to "None".

→ None : To listen in the settings you make manually.



1: To listen in the settings memorized into the memory of position 1 by the Auto Setup Trinnov Optimizer.



2: To listen in the settings memorized into the memory of the position 2.



→ 3: To listen in the settings memorized into the memory of the position 3.

When selecting the Trinnov Room EQ

- The Trinnov Room EQ is a kind of room equalizer for your speakers. According to the acoustic characteristics of your room measured by the Auto Setup Trinnov Optimizer, the Trinnov Room EQ automatically adjusts the frequency response of your speakers.

→ None : When turning off the Trinnov Room EQ.



Flat : To adjust the frequency response of all speakers to the flattest response.



A.Phile 1 : To adjust the frequency response of the speakers other than the front speakers to match the characteristics of the front speakers.



A.Phile 2 : To adjust only the low frequency response of all speakers to correct the acoustic characteristics of your room.



→ Natural : To adjust the frequency response of all speakers with a modest boost below 200 Hz and a slight cut above 10 kHz.



Continued

When selecting the Trinnov Spatial Mode

- You can select the desired of different spatial modes, which correspond to different levels of "spatial" correction.

→ None : No remapping is applied.
 ↓ ↑
 DLY + LVL (Delay + Level) : The distance and speaker levels are compensated so that all speakers seem to be the same distance from the listener and all speakers seem to be the same level.
 ↓ ↑
 Autoroute : Each input channel is routed to the nearest speaker, according to the input stream format and to the ITU standards.
 ↓ ↑
 2D Remap : No elevation compensation is done, the remapping calculation takes into account the coordinates of the speakers in the horizontal plane only.
 ↓ ↑
 → 3D Remap : The remapping matrix is computed according to all Trinnov criteria in order to produce the best spatial correction.

ENGLISH

When selecting the Trinnov Remapping

- Depending on the selected mode, the remapping matrix will be different as follows.

Cinema : The front speakers are supposed to be $+22.5^\circ$ and -22.5° from the center speaker.

↓ ↑
 Music : They are supposed to be $+30^\circ$ and -30° .

When selecting the Cinema EQ

On : To compensate for edgy or shrill movie sound tracks. ("CINEMA-EQ" lights up.)

↓ ↑
 Off : To turn off the cinema EQ function. ("CINEMA-EQ" goes off.)

When selecting the Name

- You can give names to the input sources other than tuner.
- Up to 7 characters can be entered for each name.

- Press the CURSOR UP(▲)/DOWN(▼) buttons to select "Name", then press the ENTER button.

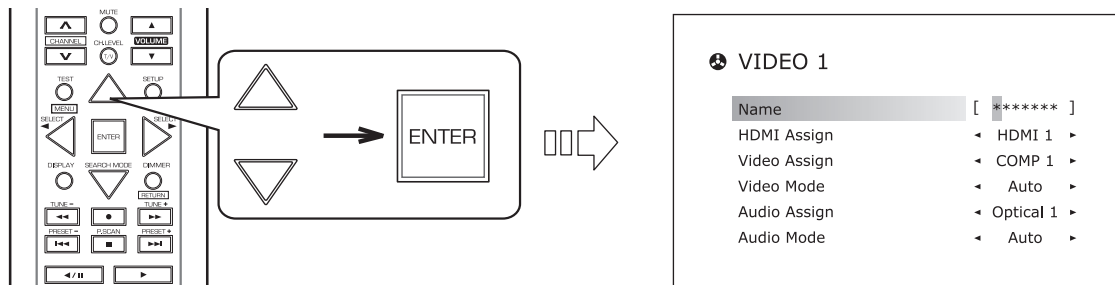



Continued

2. Press the CURSOR LEFT(◀)/RIGHT(▶) buttons to select the desired digit.

ENGLISH

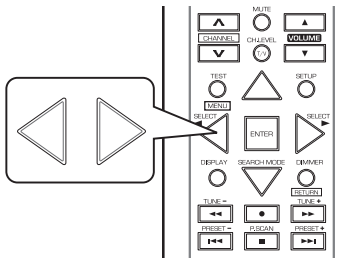

- Then the selected digit will be highlighted.

3. Press the CURSOR UP(▲)/DOWN(▼) buttons to enter the desired character on the selected digit.

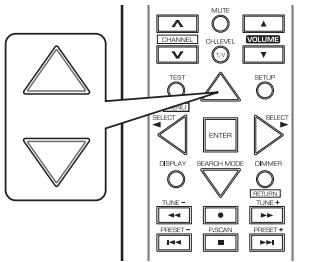

- You can enter the desired among blank, A-Z, a-z, 0-9, (,), * , +, -, ., /.

4. Repeat the above steps 2 and 3 to enter the desired characters on the rest of the digits.

5. Confirm your entry.

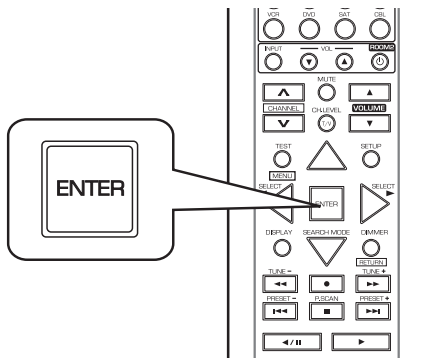

- The name is stored in the memory.
- **To resume its factory input source name.**
- Make a blank on each digit and press the ENTER button.



SETTING THE SOUND PARAMETER

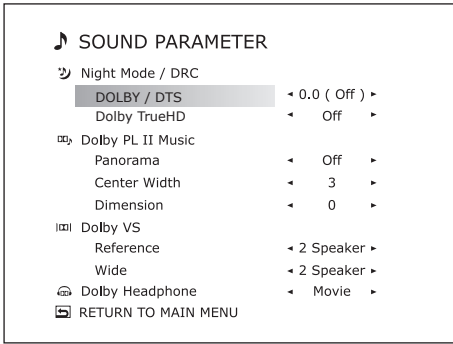

- Night Mode/DRC : To adjust the dynamic range compression that makes faint sound easier to hear at low volume levels.
- Dolby PL II Music : To adjust the various surround parameters for optimum surround effect.
- Dolby Virtual Speaker : To select the speaker layout to be used actually for each Dolby Virtual Speaker mode.
- Dolby Headphone : To select the desired listening mode for Dolby Headphone mode.

1. Press the CURSOR UP(▲)/DOWN(▼) buttons to select the desired parameter.

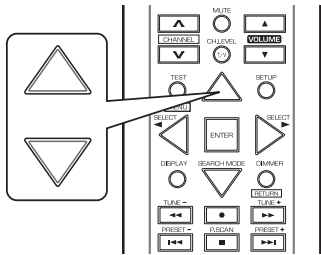

2. Press the CURSOR LEFT(◀)/RIGHT(▶) buttons to adjust the selected parameter as desired.

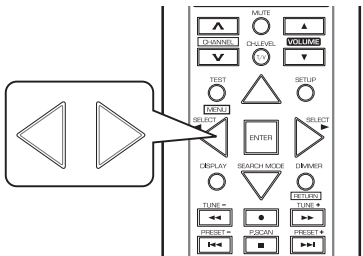

When selecting the Night Mode

- This function compresses the dynamic range of previously specified parts of the Dolby Digital, Dolby TrueHD or DTS sound track (with extremely high volume) to minimize the difference in volume between the specified and non-specified parts. This makes it easy to hear all of the sound track when watching movies at night at low levels.

■ **Notes:**

- The night mode setting is valid only when the digital signals from the Dolby Digital, Dolby TrueHD or DTS program source are being input.
- In some Dolby Digital softwares, the night mode setting may not be valid.

■ **When selecting the DOLBY/DTS**

0.0 (Off)
 ↓
 0.1
 ↓
 0.2
 :
 :
 :
 0.9
 ↓
 1.0 (Max)

↑ Lower compression

↓ Higher compression

■ **When selecting the Dolby TrueHD**

Auto : To adjust the dynamic range compression automatically.
 ↓
 On : To turn on the dynamic range compression function.
 ↓
 Off : To turn it off.



Continued

When selecting the Dolby PL II Music Parameters

- You can adjust the various surround parameters for optimum surround effect.

■ **Note:**

- The parameter settings are valid only when listening in either Dolby Pro Logic II Music mode or the Dolby Pro Logic IIx Music mode.

■ **When adjusting the Panorama mode**

This mode extends the front stereo image to include the surround speakers for an exciting "wraparound" effect with side wall imaging. Select "Off" or "On"(default value:Off).

■ **When adjusting the Center Width control**

This adjusts the center image so it may be heard only from the center speaker, only from the left/right speakers as a phantom image, or from all three front speakers to varying degrees. The control can be set in 8 steps from 0 to 7 (default value : 3).

■ **When adjusting the Dimension control**

This gradually adjusts the soundfield either towards the front or towards the rear. The control can be set in 7 steps from -3 to +3(default value : 0).

When selecting the Dolby Virtual Speaker

- You can select the speaker layout to be used actually for each Dolby Virtual Speaker mode.

■ **Notes :**

- The speaker layout settings are valid only when listening in a Dolby Virtual Speaker mode.
- When the speakers are set to "No", the corresponding speaker layouts cannot be selected.

■ **When selecting the Dolby Virtual Speaker Reference mode**

2 Speaker : When using 2 front speakers only.



3 Speaker : When using 2 front and center speakers.

■ **When selecting the Dolby Virtual Speaker Wide mode**

→ 2 Speaker : When using 2 front speakers only.



3 Speaker : When using 2 front and center speakers.



4 Speaker : When using 2 front and 2 surround speakers.



→ 5 Speaker : When using 2 front, center and 2 surround speakers.

When selecting the Dolby Headphone

- You can select the desired listening mode for Dolby Headphone mode.

■ **Note:**

- The listening mode setting is valid only when playing analog stereo, PCM 2 channel or Dolby Digital 2 channel source.

→ Movie : This provides the surround effect suitable for movie sources.



Music 1 : This provides the surround effect suitable for music sources.



→ Music 2 : This provides less surround effect compared to MUSIC 1 mode.





SETTING THE MULTI ROOM CONFIGURATION

- In addition to your main room, you can also enjoy playback in two other rooms (ROOM 2 and ROOM 3).

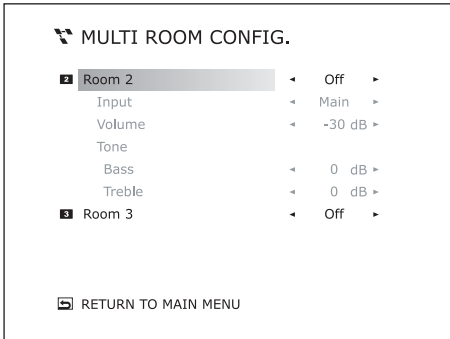

- Room 2 : To turn on or off the ROOM 2 function.
- Input : To select the desired ROOM 2 source.
- Volume : To adjust the ROOM 2 volume.
- Bass and Treble : To adjust the tone(bass and treble) for ROOM 2 source as desired.
- Room 3 : To turn on or off the ROOM 3 function.

ENGLISH

Notes:

- The analog signals from the EXTERNAL INs and the digital signals(including signals from the USB IN) cannot be output to the other rooms, meaning no playback in ROOM 2 and ROOM 3.
- The HDMI video signals and the component video signals cannot be output to the other rooms.
- When you do not use the ROOM 2 function, turn it off to save electricity.

1. Press the CURSOR UP(▲)/DOWN(▼) buttons to select the desired item.

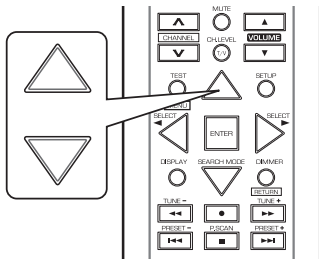

2. Press the CURSOR LEFT(◀)/RIGHT(▶) buttons to set the selected item as desired.

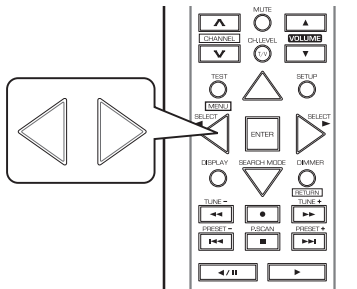

Listening to ROOM 2 source

- You can select different sources for main room and second room (ROOM 2) and play them at the same time.

When selecting the ROOM2

Off : To turn off the ROOM 2 function.



On : To turn it on.

Note:

- When the ROOM 2 is set to Off, Input, Volume, Bass and Treble for ROOM 2 cannot be selected.



Continued

■ When selecting the Input

- You can select the desired among Main source, Tuner, CD, Tape, Video 1 ~ Video 5 as a ROOM 2 source.

■ When selecting the Volume

- You can adjust the ROOM 2 volume.

■ When selecting the Bass and the Treble

- The tone level can be adjusted within the range of -10 ~ +10 dB.
- In general, we recommend the bass and treble to be adjusted to 0 dB (flat level).
- Extreme settings at high volume may damage your speakers.

Listening to ROOM 3 source

- You cannot select a different source for ROOM 3 and can play only the audio signals from the same source that you select for main room.

■ When selecting the Room 3

OFF : To turn off the ROOM 3 function.



ON : To turn it on and to play the same source that you select for main room.



SETTING THE ADVANCED CONFIGURATION

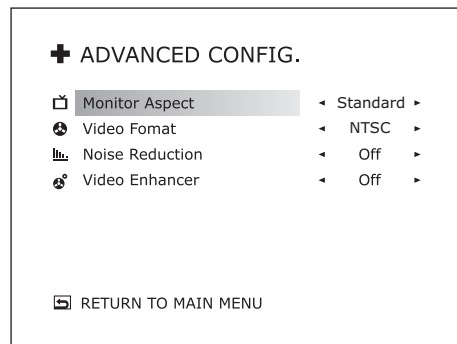

- Monitor Aspect : To select the aspect ratio of your TV's screen.
- Noise Reduction : To reduce the video noise.
- Video Enhancer : To adjust the sharpness of the picture.

■ Note:

- The Video Format is not set to anything other than NTSC.

ENGLISH

1. Press the CURSOR UP(▲)/DOWN(▼) buttons to select the desired item.

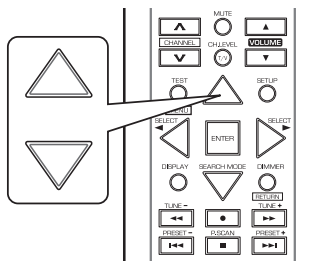

2. Press the CURSOR LEFT(◀)/RIGHT(▶) buttons to set the selected item as desired.

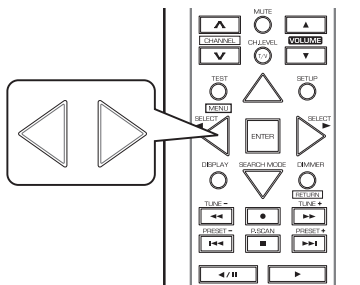

When selecting the Monitor Aspect

- Depending on the aspect ratio of your TV's screen, you can select the desired mode.

Wide : Select this when the aspect ratios of the video signal and your TV's screen are matched.



Standard : Select this when the aspect ratios of theirs are not matched.





Continued

When selecting the Noise Reduction

Off : To turn off the noise reduction function.



On : To reduce the video noise.

When selecting the Video Enhancer

Off: To turn off the video enhancer function.



On : To adjust the sharpness of the picture.

ENGLISH





SETTING THE QUICK AUDIO REFERENCE / ADJUSTMENT

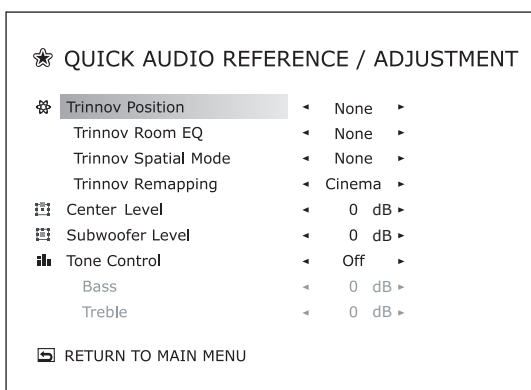

- You can make quick settings on a single menu without navigating through the different menus.

Notes :

- When the EXTERNAL IN or the USB is selected as an input source, the trinnov settings cannot be set.
- Center Level, Subwoofer Level and Tone Control can be set only when the Trinnov Position is set to "None".

ENGLISH

1. Press the CURSOR UP(▲)/DOWN(▼) buttons to select the desired item.

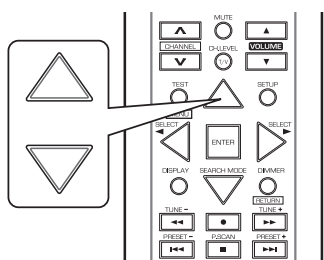

2. Press the CURSOR LEFT(◀)/RIGHT(▶) buttons to set the selected item as desired.

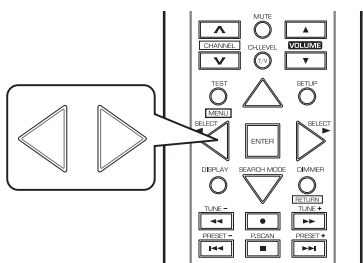

When selecting the Trinnov Position, Trinnov Room EQ, Trinnov Spatial Mode, Trinnov Remapping

- For details on each Trinnov setting, refer to "SETTING THE INPUT SETUP" on page 69.

When selecting the Center Level, Subwoofer Level

- You can adjust the level of the center or the subwoofer channel within the range of -15 ~ + 15 dB.

Note :

- Only when the Trinnov Position is set to "None", you can adjust the level of the center or the subwoofer channel.





Continued

When selecting the Tone Control

- You can adjust the tone (bass and treble) as desired.

Off : To listen to a program source without the tone effect. ("TONE" goes off.)



On : To adjust the tone for your taste. ("TONE" lights up.)

◆ When the Tone Control is set to On to adjust the tone (bass and treble)

- Press the CURSOR UP(▲)/DOWN(▼) buttons to select the desired tone mode.

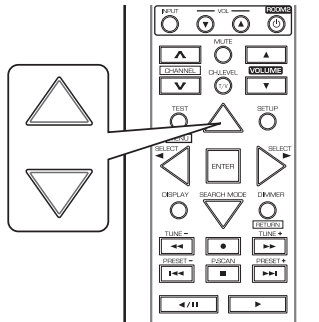

- Press the CURSOR LEFT(◀)/RIGHT(▶) buttons to adjust the selected tone as desired.

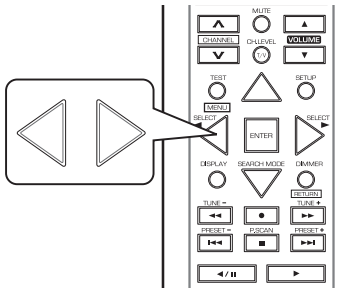

- The tone level can be adjusted within the range of -14 ~ +14 dB.
- In general, we recommend the bass and treble to be adjusted to 0 dB(flat level).
- Extreme settings at high volume may damage your speakers.
- To complete tone adjustment, repeat the above steps ① and ②.





Troubleshooting Guide

If a fault occurs, run through the table below before taking your receiver for repair.

If the fault persists, attempt to solve it by switching the receiver off and on again. If this fails to resolve the situation, consult your dealer. Under no circumstances should you attempt to repair the receiver yourself. This could void the warranty.

PROBLEM	POSSIBLE CAUSE	REMEDY
No power	<ul style="list-style-type: none"> The AC input cord is disconnected. Poor connection at AC wall outlet or the outlet is dead or off. 	<ul style="list-style-type: none"> Connect cord securely. Check the outlet using a lamp or another appliance.
No sound	<ul style="list-style-type: none"> The speaker wires are disconnected. The master volume is adjusted too low. The MUTE button is pressed to ON. Incorrect selection of input source. Incorrect connections between the components. The HDMI Audio Output is set to On. <p>The settings related to audio are set incorrectly.</p>	<ul style="list-style-type: none"> Check the speaker connections. Adjust the master volume. Press the MUTE button to cancel the muting effect. Select the desired input source correctly. Make connections correctly. Set it to Off. (For details, refer to "When selecting the HDMI Audio Output" on page 60.) Set the settings correctly. (For details, refer to "SETTING THE INPUT SETUP" on page 69.)
No sound from the surround speakers	<ul style="list-style-type: none"> Surround mode is switched off(stereo mode). Master volume and surround level are too low. Monaural source is used. Surround speaker setting is "No". 	<ul style="list-style-type: none"> Select a surround mode. Adjust master volume and surround level. Select a stereo or surround source. Select the desired surround speaker setting.
No sound from the center speaker	<ul style="list-style-type: none"> Dolby Virtual Speaker, stereo mode, etc is selected. Center speaker setting is "No". Master volume and center level are too low. 	<ul style="list-style-type: none"> Select the desired surround mode. Select the desired center speaker setting. Adjust master volume and center level.
No sound from the surround back speakers	<ul style="list-style-type: none"> The input signal format or the current surround mode cannot support the 7.1(or 6.1) surround. The surround back channels' power amplifier is assigned to "BI-AMP" or "Room 2". Master volume and surround back level are too low. Surround back speaker setting is "No". 	<ul style="list-style-type: none"> Under the proper situations, perform the 7.1(or 6.1) surround playback.(For details, refer to "ENJOYING SURROUND SOUND" on page 39.) Assign the power amplifier to the surround back channels.(For details, refer to "When selecting the AMP Assign"on page 58.) Adjust master volume and surround back level. Select the desired surround back speaker setting.
No picture	<ul style="list-style-type: none"> Video connections between this unit and the monitor TV are not made correctly. Incorrect selection of input source on the monitor TV. The settings related to video are set incorrectly. 	<ul style="list-style-type: none"> Make proper video connections. Select the input source correctly. Set the settings correctly. (For details, refer to "When selecting the Monitor Output" on page 59 and "SETTING THE INPUT SETUP" on page 69.)
No picture with an HDMI connection	<ul style="list-style-type: none"> HDMI connection between this unit and the monitor TV are not made correctly. The monitor TV or other equipments do not support HDCP. 	<ul style="list-style-type: none"> Make proper HDMI connection. This unit will not output video signal unless the connected equipments supports HDCP.
Noise or distorted picture	<ul style="list-style-type: none"> Video format of your monitor TV, DVD player, etc. is different from NTSC. 	<ul style="list-style-type: none"> Change the video format to NTSC.
Stations cannot be received	<ul style="list-style-type: none"> No antenna is connected. The desired station frequency is not tuned in. Antenna is in wrong position. 	<ul style="list-style-type: none"> Connect an antenna. Tune in the desired station frequency. Move antenna and retry tuning.
Preset stations cannot be received	<ul style="list-style-type: none"> An incorrect station frequency has been memorized. The memorized stations are cleared. 	<ul style="list-style-type: none"> Memorize the correct station frequency. Memorize the stations again.
Poor FM reception	<ul style="list-style-type: none"> No antenna is connected. The antenna is not positioned for the best reception. Weak signals. 	<ul style="list-style-type: none"> Connect an antenna. Change the position of the antenna. Install an outdoor FM antenna.
Continuous or intermittent hissing noise during AM reception, especially at night.	<ul style="list-style-type: none"> Noise is caused by motors, fluorescent lamps or lightning, etc. 	<ul style="list-style-type: none"> Keep the receiver away from noise sources. Install an outdoor AM antenna.
Remote control unit does not operate.	<ul style="list-style-type: none"> Batteries are not loaded or exhausted. The remote sensor is obstructed. 	<ul style="list-style-type: none"> Replace the batteries. Remove the obstacle.
OSD function is not available.	<ul style="list-style-type: none"> Video connections between this unit and the monitor TV are not made correctly. 	<ul style="list-style-type: none"> Make proper video connections.



Specifications

■ AMPLIFIER SECTION

- Power output, stereo mode, 8 Ω , 20 Hz to 20 kHz, 2 x 100 W RMS
- Total harmonic distortion, 8 Ω , 1 kHz, 0.02%
- Intermodulation distortion
60 Hz : 7 kHz = 4 : 1 SMPTE, 8 Ω , 0.02%
- Input sensitivity/impedance
Line (CD, TAPE, VIDEO) | 230 mV/47k Ω
- Signal to noise ratio, IHF "A" weighted
Line (CD, TAPE, VIDEO) | 100 dB
- Frequency response
Line (CD, TAPE, VIDEO), 10 Hz - 100 kHz | +0, -3 dB
- Output level
TAPE, ROOM 2, ROOM 3 OUT, 2.2 k Ω | 200 mV
PREOUT (Front, Center, Surround, Surround back, Subwoofer), 1 k Ω | 1.0 V
- Bass/Treble control, 100 Hz/10 kHz | ± 14 dB
- Surround mode, only channel driven
Front power output, 8 Ω , 1 kHz, THD 1.0 % | 130 W / 130 W
Center power output, 8 Ω , 1 kHz, THD 1.0 % | 130 W
Surround power output, 8 Ω , 1 kHz, THD 1.0 % | 130 W / 130W
Surround back (MULTI) / ROOM 2 power output, 8 Ω , 1 kHz, THD 1.0 % | 130 W / 130W

■ DIGITAL AUDIO SECTION

- Sampling frequency | 32, 44.1, 48, 96, 192 kHz
- Digital input level
Coaxial, 75 Ω | 0.5 Vp-p
Optical, 660 nm | -15 ~ -21 dBm

■ VIDEO SECTION

- Video format | NTSC / PAL
- Input sensitivity(=Output level), 75 Ω
Video (Composite(normal)) | 1 Vp-p
S-Video (luminance signal) | 1 Vp-p
(chrominance signal) | 0.286 Vp-p
Component video (R-Y signal) | 0.53 Vp-p
(B-Y signal) | 0.53 Vp-p
(Y signal) | 1.0 Vp-p
- HDMI connector | 19 pin

■ FM TUNER SECTION

- Tuning frequency range | 87.5~108 MHz
- Usable sensitivity, THD 3%, S/N 30 dB | 12.8 dBf
- 50 dB quieting sensitivity, mono/stereo | 20.2 / 45.3 dBf
- Signal to noise ratio, 65 dBf, mono/stereo | 70 / 65 dB
- Total harmonic distortion, 65 dBf, 1 kHz, mono/stereo | 0.5 / 0.8 %
- Frequency response, 30 Hz-15 kHz | ± 1 dB
- Stereo separation, 1 kHz | 42 dB
- Capture ratio | 1.25 dB
- IF rejection ratio | 120 dB

■ AM TUNER SECTION

- Tuning frequency range | 520~1710 kHz
- Usable sensitivity | 500 μ V/m
- Signal to noise ratio | 40 dB
- Selectivity | 25 dB

■ RF REMOTE SECTION

- Operating frequency | 2.433 GHz \pm 100 kHz
- RF range | 15 ~ 30 meters (50 ~ 100 feet), depending on the environment
- Sensitivity | Min. -90 dBm

■ GENERAL

- Power supply | 120 V ~ 60 Hz
- Power consumption | 6 A
- Switched AC outlets | TOTAL 120 W (1 A) max.
- Dimensions (W x H x D, including protruding parts) | 440 x 199 x 490 mm (17-3/8 x 7-7/8 x 19-1/4 inches)
- Weight (Net) | 18.5 kg (40.8 lbs)

Note: Design and specifications are subject to change without notice for improvements.

Setup Code Table

TV

AOC	005	003			
Admiral	041	031			
Aiko	014				
Akai	005				
Alaron	026				
Ambassador	024				
America Action	027				
Ampro	043				
Anam	027	047	048	049	
Audiovox	030	027	014	034	
Baysonic	027				
Belcor	003				
Bell & Howell	019	001			
Bradford	027				
Brockwood	003				
Broksonic	028	031			
CXC	027				
Candle	005	011			
Carnivale	005				
Carver	010				
Celebrity	050				
Cineral	030	014			
Citizen	012	005	011	006	014
Concerto	011				
Contec	027				
Craig	027				
Crosley	010				
Crown	027	006			
Curtis Mathes	007	010	019	008	030 041
	012	005	016	011	001 006
	022	032	038	040	
Daewoo	030	003	006	014	034 035
Daytron	003				
Denon	016				
Dumont	002	003			
Dwin	044	036			
Electroband	050				
Emerson	019	028	031	027	029 025
	003	026	006	024	034 035
Envision	005				
Fisher	019				
Fujitsu	026				
Funai	027	026	023		
Futuretech	027				
GE	007	008	030	041	029 025
	004	015	038	040	
Gibraltar	002	005	003		

Goldstar	005	025	003	011	
Gradiente	009	011			
Grunpy	027	026			
Hallmark	025				
Harley Davidson	026				
Harman/Kardon	010				
Havard	027				
Hitachi	016	011	018		
Infinity	010				
Inteq	002				
JBL	010				
JCB	050				
JVC	009	046			
KEC	027				
KTV	027	005	006		
Kenwood	005	003			
LG	011				
LXI	007	010	019	020	025
Logik	001				
Luxman	011				
MGA	017	005	025	003	
MTC	012	005	003	011	
Magnavox	010	005	026		
Majestic	001				
Marantz	010	005			
Matsushita	042				
Magatron	025	016			
Memorex	019	042	031	017	025 011
	001				
Midland	007	002	008	006	015
Minutz	004				
Mitsubishi	041	017	025	003	
Motorola	041				
Multitech	027				
NAD	020	025	022		
NEC	005	003	011		
NTC	014				
Nikko	005	025	014		
Onwa	027				
Optimus	019	042	022		
Optonica	041	021			
Orion	028	031	026		
Panasonic	008	042			
Penney	007	020	008	012	005 025
	004	003	011	006	015 040
Pilco	010	031	005	016	003
Philips	010				

Pilot	005	003	006			
Pioneer	022					
Portland	003	006	014			
Prism	008					
Proscan	007					
Proton	025	032				
Pulsar	002	003				
Quasar	008	042	021			
RCA	007	008	041	003	013	015
	037	038	039	040		
Radio Shack	007	019	021	027	005	025
	003	011	006			
Realistic	019	021	027	005	025	003
	011	006				
Runco	002	005	033			
SSS	027	003				
Sampo	005	006				
Samsung	012	005	025	003	011	045
Samsux	006					
Sansei	030					
Sansui	031					
Sanyo	019					
Scimitsu	003					
Scotch	025					
Scott	028	027	025	003	026	
Sears	007	010	019	020	025	026
	011	023				
Semivox	027					
Semp	020					
Sharp	041	021	006			
Sherwood	000					
Shogun	003					
Signature	001					
Sony	050					
Soundesign	027	025	026			
Squareview	023					
Starlite	027					
Supreme	050					
Sylvania	010	005				
Symphonic	023					
TMK	025	011	024			
Tandy	041					
Technics	008	042				
Technoi Ace	026					
Techwood	008	011				
Teknika	010	027	017	012	003	026
	011	001	006	014		
Telefunken	011					
Toshiba	019	020	012			
Totevision	006					
Vector Research	005					
Victor	009					
Vidikron	010					

Vidtech	025	003				
Wards	010	021	005	025	004	003
	026	011	001			
White Westinghouse	031	034	035			
Yamaha	005	003				
Zenith	002	031	001	014		

VCR

Admiral	027	021				
Adventura	000					
Aiko	025					
Aiwa	005	000				
Akai	026					
America Action	025					
America High	004					
Asha	023					
Audiovox	005					
Beaumarck	023					
Bell & Howell	017					
Brocksonic	021					
Broksonic	020	018	021	001		
CCE	015	025				
Calix	005					
Canon	004					
Carver	016					
Cineral	025					
Citizen	005	025				
Colt	015					
Craig	005	012	023	015	024	
Curtis Mathes	013	004	026	028		
Cybernex	023					
Daewoo	010	025				
Denon	008					
Dynatech	000					
Electrohome	005					
Electroponic	005					
Emerex	002					
Emerson	005	020	000	018	009	021
	001	025				
Fisher	012	017				
Fuji	004	003				
Funai	000					
GE	013	004	027	023		
Garrard	000					
GoldStar	005	006				
Gradiente	000					
HI-Q	012					
Harley Davidson	000					
Harman/Kardon	016	006				
Harwood	015					

Headquarter	011					
Hitachi	000	008	026			
JVC	014	026				
Jensen	026					
KEC	005	025				
KLH	015					
Kenwood	014	026	006			
Kodak	004	005				
LXI	005					
Lloyd's	000					
Logik	015					
MEI	004					
MGA	023	009				
MGN Technology	023					
MTC	023	000				
Magnasonic	025					
Magnavox	004	007	016	000	019	
Magnin	023					
Marantz	004	016				
Marta	005					
Matsushita	004	028	029			
Memorex	004	005	027	007	012	023
	000	017	021	011	031	032
Minolta	008					
Mitsubishi	027	014	009			
Motorola	004	016				
Multitech	000	015				
NEC	017	014	026	006		
Nikko	005					
Noblex	023					
Olympus	004					
Opimus	005	027	017	028	029	030
	031	032				
Orion	020	021	001			
Panasonic	004	028	022	029	031	
Penny	004	005	023	008	006	
Pentax	008					
Philco	004	021				
Philips	004	016				
Pilot	005					
Pioneer	014					
Profitronic	023					
Proscan	013					
Protec	015					
Pulsar	007					
Quarter	011					
Quartz	011					
Quasar	004	028	029	031		
RCA	013	004	027	023	008	019
Radio Shack	000					
Radix	005					
Randex	005					

Realistic	004	005	027	012	000	017
	011					
Runco	007					
STS	008					
Samsung	023	010	033			
Sanky	027	007				
Sansui	000	014	021	026	024	
Sanyo	012	023	017	011		
Scott	020	010	018	009		
Sears	004	005	012	000	008	017
	011					
Semp	010					
Sharp	027					
Shintom	015					
Shogun	023					
Singer	015					
Sony	004	002	000	003		
Sylvania	004	016	000	009		
Symphonic	000					
TMK	023					
Tatung	026					
Teac	000	026				
Technics	004	028				
Teknika	004	005	000			
Thomas	000					
Toshiba	010	009				
Totevision	005	023				
Unitech	023					
Vector	010					
Vector Research	006					
Video Concepts	010					
Videosonic	023					
Wards	013	004	027	012	016	023
	000	008	015	019		
White WestingHouse	021	025				
XR-100	004	000	015			
Yamaha	006					
Zenith	007	000	021	003		

ENGLISH

VCR - TV/VCR

Ameira High	004 (TV use 008)				
Brocksonic	001				
Colt	015				
Cutis Mathes	004 (TV use 008)				
Daewoo	025				
Emerson	001				
Funai	000				
GE	004 (TV use 008)	013 (TV use 007)			
	027 (TV use 041)	023			
Hitachi	004 (TV use 008)	000			

HQ	000
Lloyds	000
MGA	023
Megavox	016 (TV use 010) 004 (TV use 008)
	000
Magnin	023
Memorex	005 028 (TV use 042)
Mitsubishi	027 (TV use 041)
Orion	001
Panasonic	004 (TV use 008) 028 (TV use 042)
Penney	004 (TV use 008) 023
	028 (TV use 042)
Quasar	004 (TV use 008) 028 (TV use 042)
RCA	013 (TV use 007) 004 (TV use 008)
	027 (TV use 041)
Sansui	000
Sanyo	023
Sear	000 005
Sharp	027 (TV use 041)
Sony	002 (TV use 050)
Symphonic	000
Zenith	000

DVD

Apex	015
Harman/Kardon	009
JVC	008
Kenwood	005
Megavox	024
Mitsubishi	001
Onkyo	024
Panasonic	013
Philips	024 006
Pioneer	003 014 026
Proscan	002
RCA	002
Samsung	017
Sherwood	001 023 012 011 000 016
	018 019 020 021 022
Sony	004
Technics	013
Theta Digital	014
Toshiba	024
Yamaha	013 007
Zenith	024 010

CBL

ABC	002 003 009 030 006 008
	037 107 036 059 062 066
	072
Adelphia	063 085
Allegro	018 021
Altrio	063
Americast	103
Archer	018 026 038 040 047
Armstrong	085
AT&T Broadband	085
Atlantic Broadband	063 085
Bell South	103
Bell&Howell	009
Blue Ridge	063 085
Bresnan	085
Bright House	063 114
Buckeye Comm	085
Cablevision	063 085 112
Centurion	096
Century	018 040
Charter	063 085
Citizen	018 021 040
Cogeco	085
Combano	089 090
Comcast	063 085 114
Comsat	085
Comtronics	014
Contec	011
Cox Digital	063 085
Digicable	105
Eagle	050 052 060
Eastern	001 076 081
Echostar	110
Electricord	054
Emerson	026
Everquest	010 014
Focus	022
Garrard	018
Gemini	010 041 073
General Electric	084
General Instrument	033 032 006 034 085 107
	108
GNC	103
Golden Channel	052
GoldStar	017 014
Goodmind	026
Hamlin	012 020 004 013 068 069
	074

Hitachi	006	107	074			
Insight	085					
Jasco	010	018	021			
Jerrold	002	007	033	032	009	010
	006	034	035	036	037	041
	042	043	082	085	107	
Magnavox	043	045	080	088	099	098
Massillon	085					
Media One	111					
Medicom	074					
Memorex	000	071				
Mitsubishi	106					
Motorola	085	114	113	106		
Movie Time	015	028	054			
Moxi	106					
Nctc	085					
NSC	015	048	051	058	083	
Oak	011	053	057	072		
Optimus	031					
Pace	063	085				
Panasonic	000	016	031	064	067	
Paragon	000	071				
Philips	018	039	045	046	050	091
	099					
Pioneer	017	025	063	107	055	070
	079	086	109			
Popular Mechanics	022					
Prucer	077					
Pulsar	000	071				
Quasar	000					
RCA	031	067				
Radio Shack	010	021	026	028		
Recoton	022	102				
Regal	012	020	068	069		
Regency	001	076				
Rembrandt	006					
Rodgers	063					
Runco	000					
Samsung	017	014	052			
Scientific Atlanta	003	023	030	027	063	044
	036	061	062	065	066	
Seren	063					
Service Electric	085					
Shaw	085					
Sherwood	000					
Sigecom	063					
Signal	010	014				
Signature	006					
SL Marx	014					
Sony	100	112				
Sprucer	031	067	087			
Starcom	002	010	035	037	041	042

Stargate	010	014	026	041	052	101
	108					
Starquest	010					
Susquehanna	063	085				
Televue	014					
Time Warner	063	085				
Tocom	007	008	059	060	075	
Toshiba	000	071				
Tusa	010					
TV86	015					
Unika	018					
United Cable	037	072				
Universal	018	019	038	040	047	054
	056					
Videotron	063					
Viewstar	015	045	048	049	092	093
	094	095				
Wide Open West	063	103				
Zenith	000	024	071	078	097	104
Zentek	022					

SAT

AlphaStar	008					
Cablevision/voom	031					
Chaparral	001					
Directv	053					
Echostar/dish	009	024	049	050		
Expreevu	009					
Expressvu	024					
General Electric	033	021	032			
General Instrument	016	015	018	031		
Goi	024					
Hitachi	011	028	029			
HTS	009	024				
Hughes	043	044	019	036	047	048
	022	023				
Hughes Net.Sys	007					
JVC	009	024				
Jerrold	016	015				
LG	052					
Magnavox	027					
Megavox	006	005				
Memorex	006					
Mitsubishi	019	036				
Motorola	031					
Next Level	018	031				
Panasonic	017	030	042			
Pansat	027					
Philips	006	005	034	035	038	019
	036	027	022	023		

ENGLISH

Primestar	016	015				
Proscan	033	021	032			
Radio Shack	018	031				
RCA	003	000	002	012		
Realistic	014					
RSA	033	021	032			
Samsung	025	037	045	051	054	
Sherwood	000					
SKY	046					
Sony	004	020				
Star Choice	018	031				
Toshiba	010	026	019	036	039	040
Uniden	006	005	014	027		
Zenith	013	041				

AUX-MD

Sherwood	035 (for Mini Disc)
----------	---------------------

AUX-LD

Denon	007	
Mitsubishi	007	
NAD	007	
Pioneer	007	
Sony	017	018

AUX-TAPE

Aiwa	004	034		
Carver	004			
Harman/Kardon	016	004		
JVC	022	024		
Kenwood	008			
Megavox	004			
Marantz	004			
Onkyo	012	025		
Opimus	002	020		
Panasonic	038			
Pioneer	002	019	011	
Sansui	004			
Sherwood	000			
Sony	021	014	026	
Technics	038			
Victor	024			
Wards	002			
Yamaha	010	009		

AUX-CD AMP

Aiwa	030	
Carver	023	
Curtis Mathes	027	
Denon	037	
Harman/Kardon	040	
Linn	023	
Megavox	023	
Marantz	023	
Panasonic	039	
Philips	023	040
Pioneer	003	027
Sony	019	033
Technics	039	
Wards	003	
Yamaha	028	

AUX-HOME AUTOMATION

GE	043
Lutron	044
One For All	042
Radio Shack	043
Security System	042
Universal X10	042
X10	042

AUX-DBS

Aiwa	045	029
Fisher	005	
Harman/Kardon	046	
JBL	046	
JVC	047	
Jerrold	031	
RCA	006	
Scientific Atlanta	032	
Sony	045	
Starcom	031	

AUX-VIDEO ACCESSORY

Archer	013
GC Electronics	013
Jebsee	013
Rabbit	036
Radio Shack	013
Telecaption	015

CD

Aiwa	010	030			
Burmester	019				
California Audio Lab	002				
Carver	010	012	020		
DKK	001				
Denon	028	034			
Emerson	035				
Fisher	012	033			
Garrard	019	018			
Genexxa	004	035			
Harman/Kardon	010	011			
Hitachi	004				
JVC	007				
Kenwood	003	029	016	024	025
Krell	010				
LXI	035				
Linn	010				
MCS	002				
MTC	019				
Megavox	010	035			
Marantz	002	010	013		
Mission	010				
NSM	010				
Nikko	033				
Onkyo	008	026			
Opimus	001	004	012	035	029
	019	009	021	020	
Panasonic	002	031			
Parasound	019				
Philips	010	023			
Pioneer	004	035	021	017	
Proton	010				
QED	010				
Quasar	002				
RCA	012	035	006	036	
Realistic	012	019	013		
Rotel	010	019			
SAE	010				
Sansui	010	035			
Sanyo	012				
Scott	035				
Sears	035				
Sharp	029	013	037		
Sherwood	013	027	038	039	040 041
	000				
Sony	001	014	022		
Soundesign	009				

Tascam	019			
Teac	019	018	033	013
Technics	002	031		
Victor	007			
Wards	010	006		
Yamaha	005	015		
Yorx	032			

ENGLISH



R-972

Audio/Video Receiver

